

0 143

U 10 / U 10 SPRAY / U 13

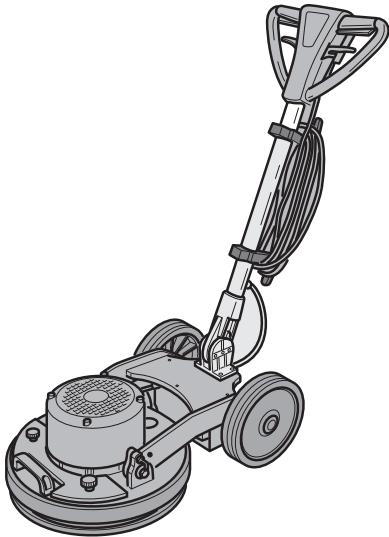

EN Use and Maintenance

CE

GH30-937
ed. 10/2025



IT

DATI IDENTIFICATIVI

I dati identificativi e la marcatura "CE" della macchina sono posizionati sulla targhetta posta sul corpo macchina.

Si consiglia di trascrivere il modello della macchina e il relativo numero di matricola nella tabella riportata nella pagina seguente.

EN

IDENTIFICATION DATA

The machine identification data and "CE" marking are located on the plate on the machine body.

It is advisable to note the machine model and serial number on the table on the next page.

FR

DONNÉES D'IDENTIFICATION

Les données d'identification et le marquage « CE » de la machine se trouvent sur la plaque située sur le corps de la machine.

Nous vous conseillons de recopier le modèle de la machine et le numéro de matricule correspondant dans le tableau reporté sur la page suivante.

DE

KENNDATEN

Die Maschinenkenndaten und die Aufprägung "CE" befinden sich auf dem Schild an der Maschine.

Wir empfehlen, das Maschinenmodell und die dazugehörige Seriennummer in die Tabelle auf der nachfolgenden Seite einzutragen.

ES

DATOS DE IDENTIFICACIÓN

Los datos de identificación y la marca "CE" de la máquina están grabados en la placa colocada sobre la estructura de la máquina.

Se recomienda transcribir el modelo y el número de matrícula de la máquina en la tabla descrita en la siguiente página.

PT

DADOS IDENTIFICATIVOS

Os dados identificativos e a marcação "CE" da máquina estão na placa colocada no corpo da máquina.

Aconselha-se transcrever o modelo da máquina e o relativo número de série na tabela referida na página seguinte.

NL

IDENTIFICATIEGEGEVENS

De identificatiegegevens en de "CE"-markering van de machine bevinden zich op het plaatje dat op de machine is aangebracht.

We raden u aan het model en het serienummer van de machine in de tabel op de volgende pagina te vermelden.

CS**IDENTIFIKAČNÍ ÚDAJE**

Identifikační údaje a označení stroje „CE“ jsou uvedeny na štítku umístěném na tělese stroje. Doporučujeme, abyste model stroje a jeho příslušné výrobní číslo přepsali do tabulky uvedené na následující straně.

RU**ИДЕНТИФИКАЦИОННЫЕ ДАННЫЕ**

Идентификационные данные машины и маркировка «CE» находятся на табличке, установленной на корпусе машины.

Рекомендуется переписать модель машины и соответствующий паспортный номер в таблицу, приведенную на следующей странице.

PL**DANE IDENTYFIKACYJNE**

Dane identyfikacyjne i oznakowanie "CE" urządzenia umieszczone są na tabliczce znamionowej znajdującej się na korpusie urządzenia.

Zaleca się wpisać model i numer seryjny urządzenia do tabeli znajdującej się na kolejnej stronie.

AR**معلومات التعريف**

إن معلومات التعريف وعلامة "سي إي" للألة موجودة غي لوحة التعريف على هيكل الألة. ينصح كتابة موديل الألة والرقم المتسلسل في الجدول المذكور في الصفحات الآتية.

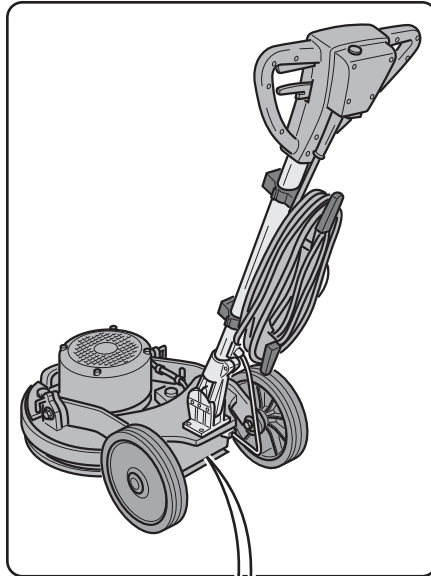

1	2
Single Disc V ~ Hz W	Mod: Art.: Year:
Working Ø: mm Weight: kg	Speed: rpm S/N:
7	3
9	8
4	6
5	5

	1	2	3	4	5
IT	Produttore	Modello	Codice articolo	Ø di lavoro	Velocità di rotazione
EN	Manufacturer	Model	Article code	Working Ø	Rotation speed
FR	Producteur	Modèle	Code de l'article	Ø de travail	Vitesse de rotation
DE	Hersteller	Modell	Artikelnummer	Ø Arbeit	Drehgeschwindigkeit
ES	Fabricante	Modelo	Código del artículo	Ø de trabajo	Velocidad de rotación
PT	Fabricante	Modelo	Código do artigo	Ø de trabalho	Velocidade de rotação
NL	Producent	Model	Artikelcode	Ø bewerking	Rotatiesnelheid
CS	Výrobce	Model	Kód výrobku	Pracovní Ø	Rychlost rotace
RU	Изготовитель	Модель	Код изделия	Рабочий Ø	Скорость вращения
PL	Producent	Model	Kod artykułu	Ø pracy	Prędkość obrotów
AR	الصانع	الموديل	الرمز	قطر العمل	سرعة الدوران

	6	7	8	9
IT	N° Matricola	Caratteristiche elettriche	Anno di costruzione	Peso macchina
EN	Serial number	Electrical characteristics	Year of construction	Machine weight
FR	N° de Matricule	Caractéristiques électriques	Année de construction	Poids de la machine
DE	Serien-Nr.	Elektrische Eigenschaften	Baujahr	Maschinengewicht
ES	N° de Matricula	Características eléctricas	Año de fabricación	Peso de la máquina
PT	N° de Série	Características eléctricas	Ano de construção	Peso da máquina
NL	Serienummer	Elektrische eigenschappen	Bouwjaar	Machine gewicht
CS	Výrobní č.	Elektrické v lastnosti	Rok výroby	Hmotnost stroje
RU	N° Паспорта	Электрические характеристики	Год выпуска	Вес машины
PL	Nr seryjny	Charakterystyka elektryczna	Rok produkcji	Ciężar maszyny
AR	الرقم المتسلسل	المواصفات الكهربائية	سنة الصنع	وزن الآلة

Fig. 1

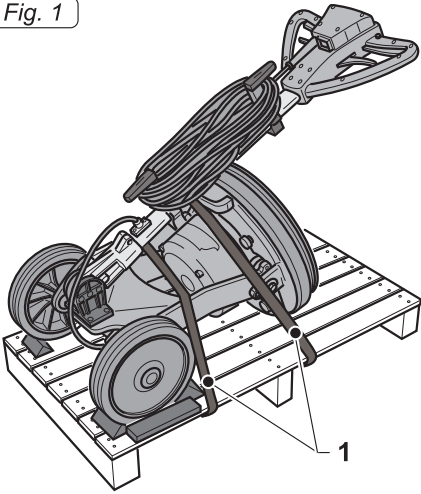

Fig. 2

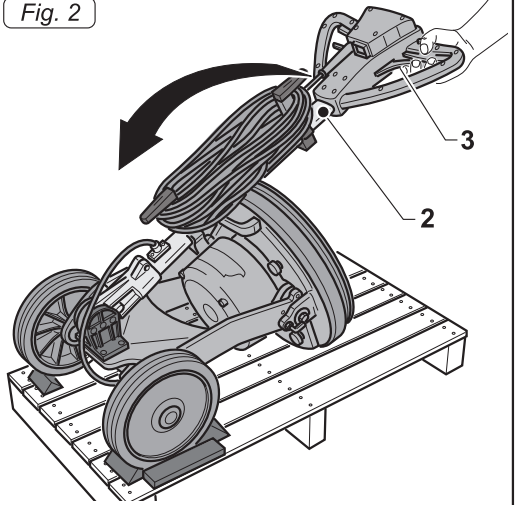

Fig. 3

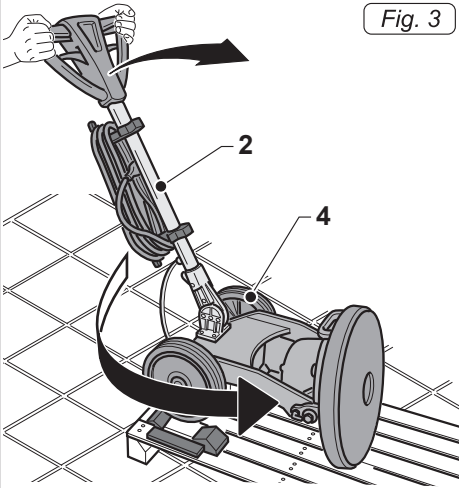

Fig. 4

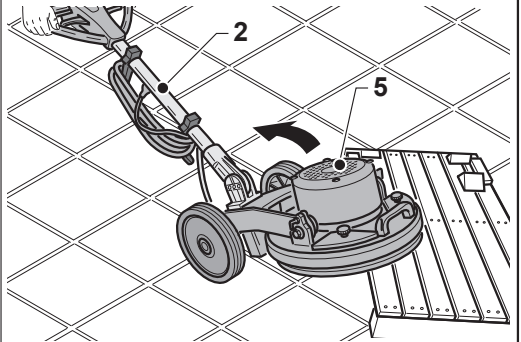
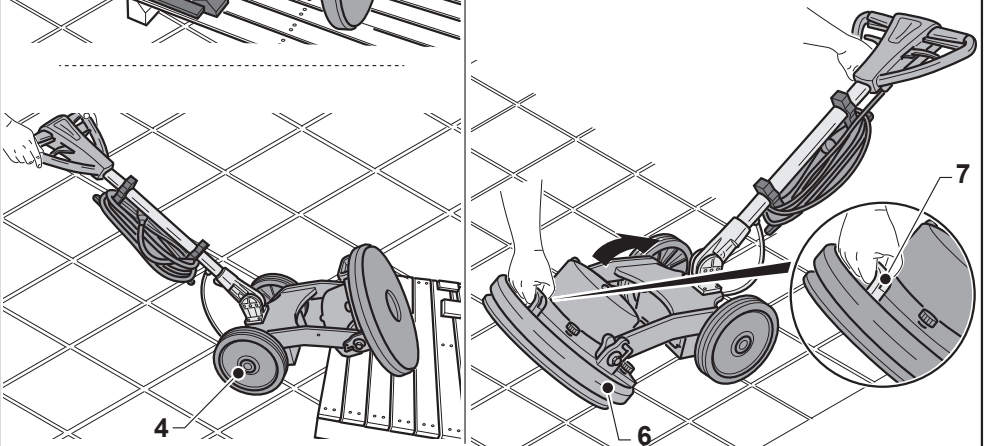

Fig. 5



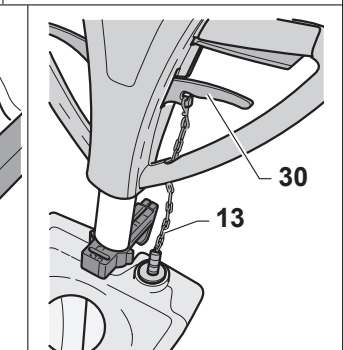
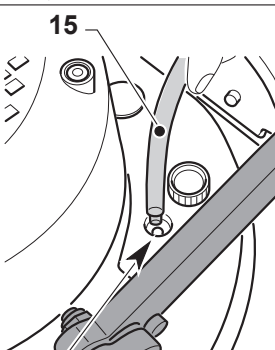
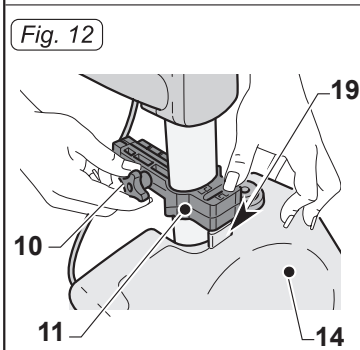
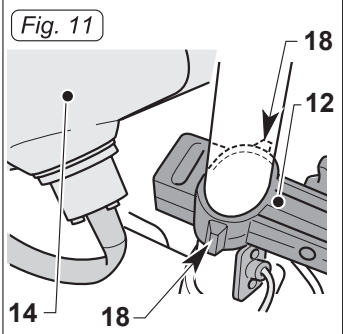
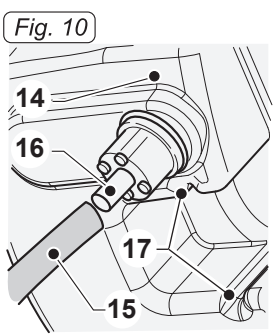
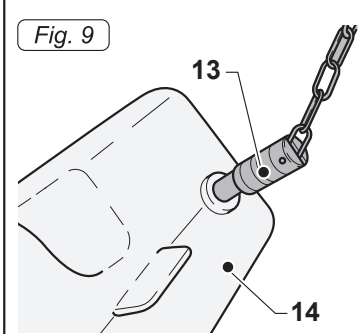
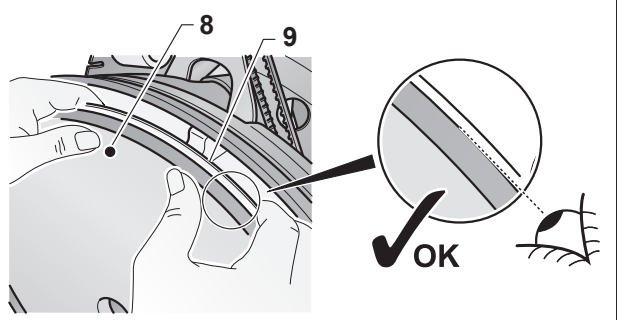
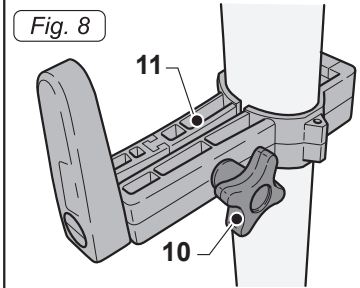
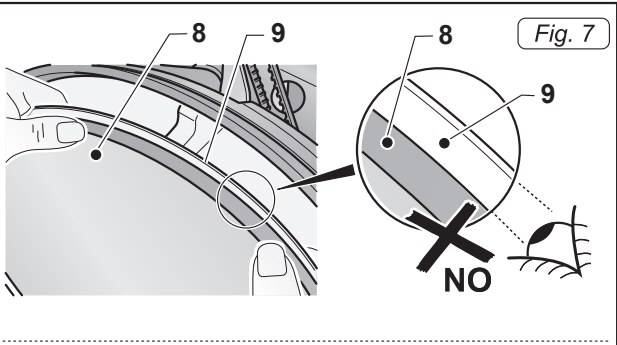
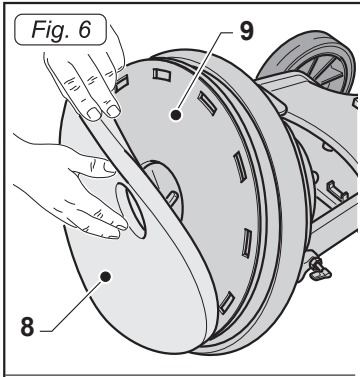

Fig. 15

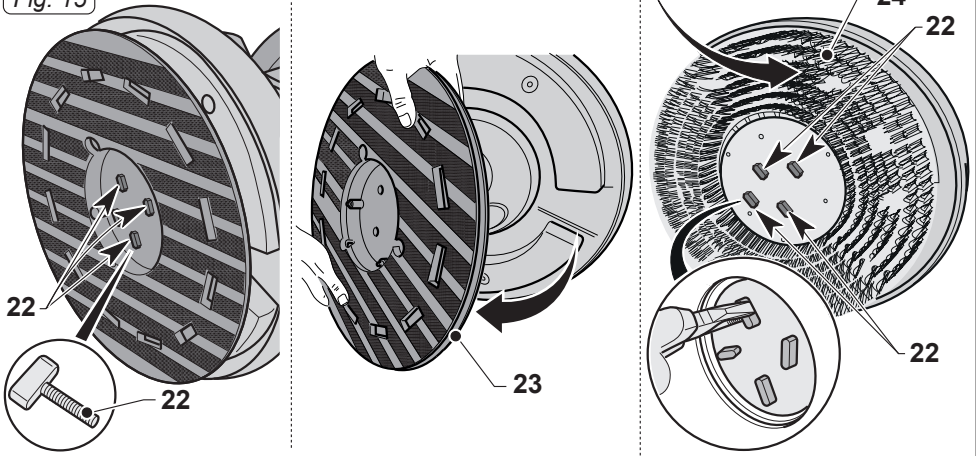

Fig. 16

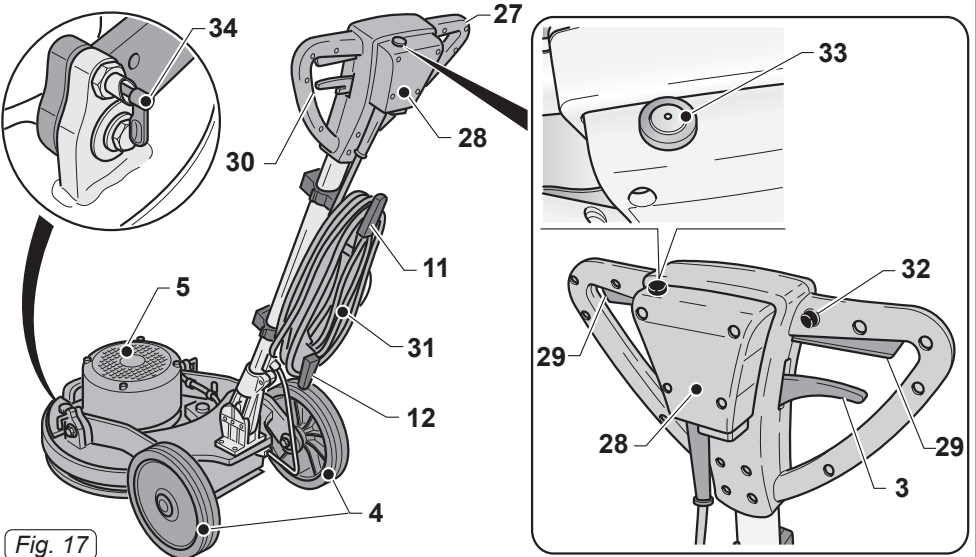
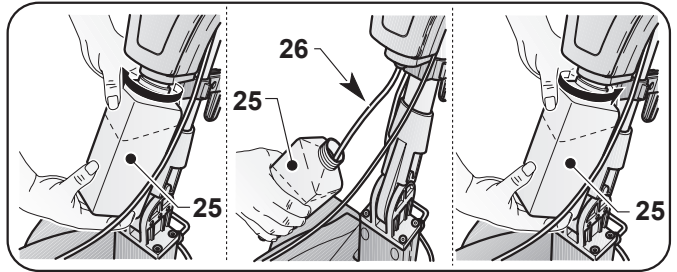
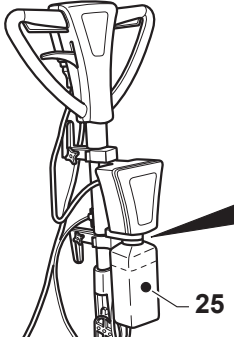

Fig. 17

Fig. 18

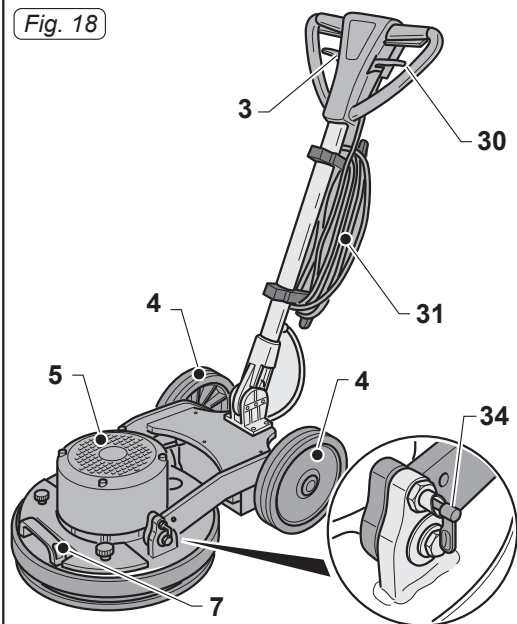

Fig. 19

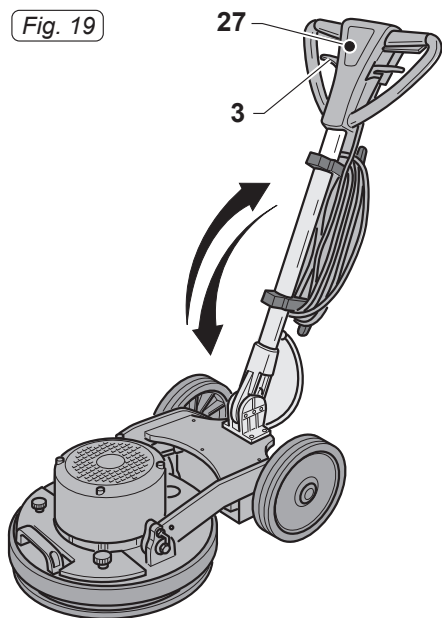

Fig. 20

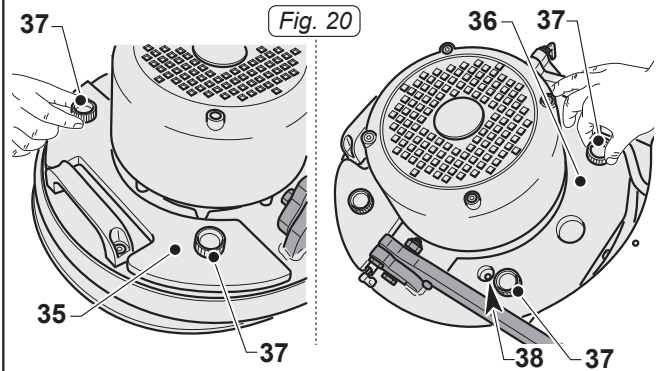

Fig. 21

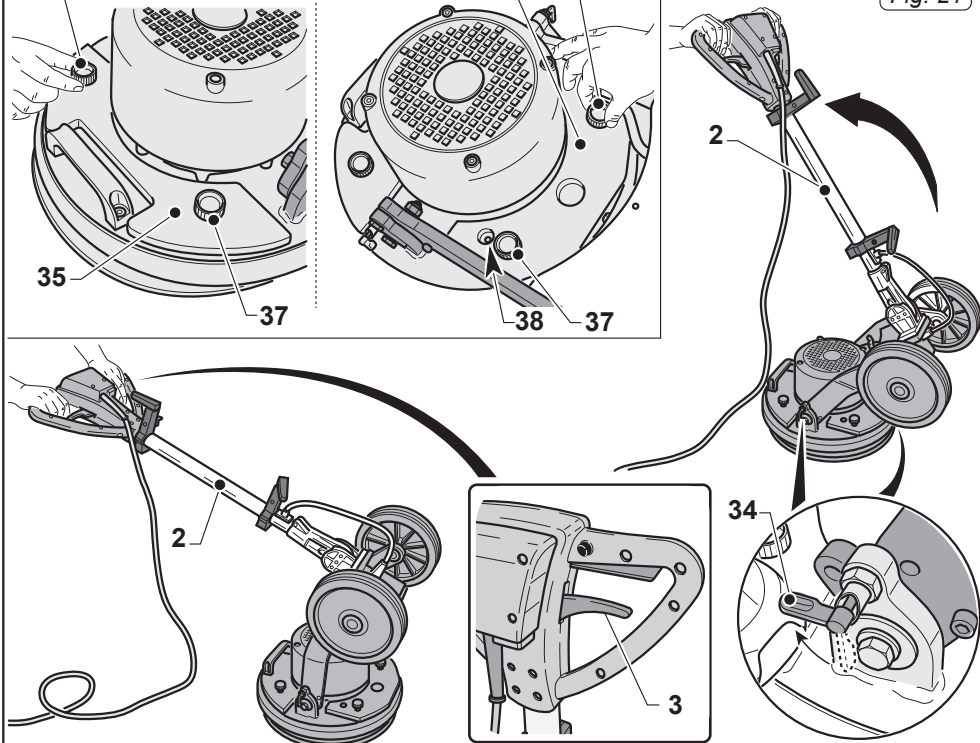

Fig. 22



Fig. 23

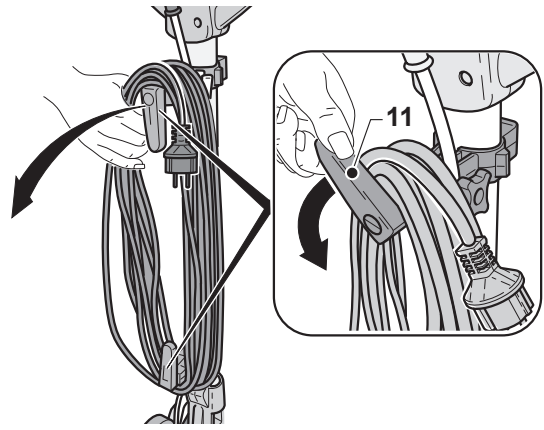

Fig. 24

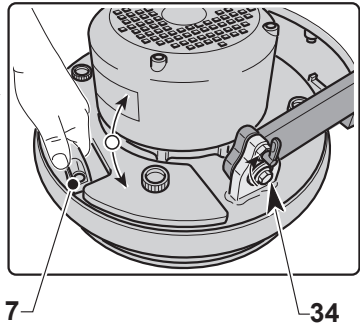
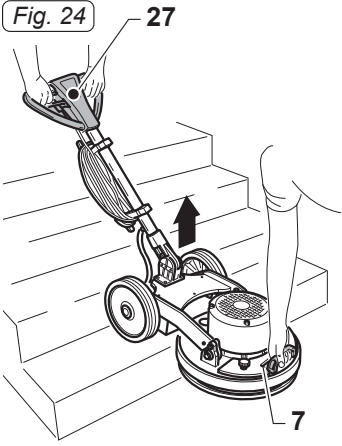

Fig. 25

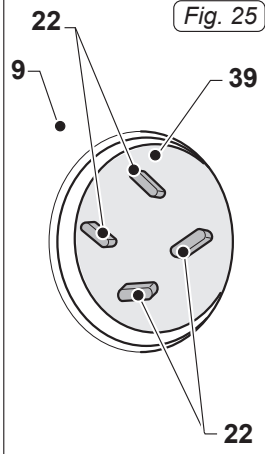

Fig. 26

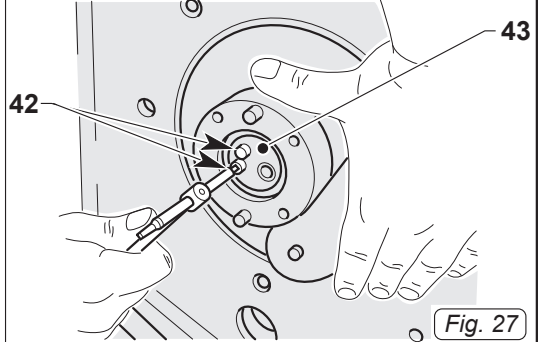
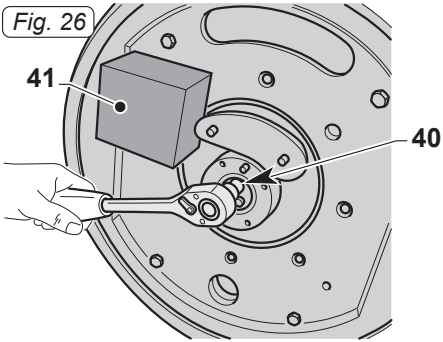

Fig. 27

Fig. 28

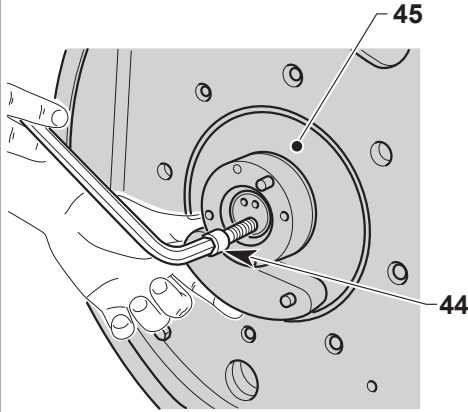
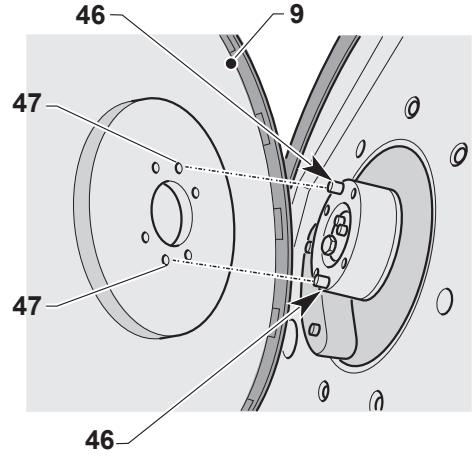

Fig. 29



EN

English ENGLISH - 1
(Translation of original instructions)

*Dear Customer,
Thank you for choosing one of our cleaning products.*

The floor cleaner you have purchased has been designed to satisfy users in terms of ease of use and reliability.

We are aware that, in order to remain so over time, a good product requires continuous updates aimed at satisfying the expectations of those who use it daily. To this end, we hope that you will be not only a satisfied customer but also a partner who does not hesitate to let us know your views and ideas resulting from personal experience on a day-to-day basis.

Contents

1.1 TECHNICAL CHARACTERISTICS	EN-3
1.2 INTRODUCTION	EN-3
1.3 INTENDED USE OF THE MACHINE	EN-3
1.4 NON-INTENDED USE OF THE MACHINE	EN-3
2.1 UNPACKING	EN-4
2.2 COMPONENT ASSEMBLY	EN-4
2.2.a - Pad assembly.....	EN-4
2.2.b - Assembling the tank (optional).....	EN-4
2.2.c - Electrical spray accessory assembly (Optional).....	EN-4
2.2.d - Brush assembly (optional)	EN-4
2.2.e - Filling the electrical spray tank (optional)	EN-4
2.2.f - Electrical connection	EN-5
3.1 KNOWLEDGE OF THE MACHINE	EN-5
4.1 HANDLE TILT ADJUSTMENT	EN-5
5.1 GUIDE HANDLE	EN-6
6.1 OPERATION	EN-6
6.1.a - Checks to be performed before use.....	EN-6
6.1.b - Additional weights assembly	EN-6
6.1.c - Starting the machine	EN-6
6.1.d - Using the machine	EN-7
6.1.e - Use with overturned handle.....	EN-7
6.1.f - End of use and shutdown	EN-7
6.1.g - Transport.....	EN-7
7.1 MAINTENANCE AND CLEANING	EN-7
7.1.a - Cleaning the machine.....	EN-8
7.1.b - Emptying and cleaning the water tank (optional)	EN-8
7.1.c - Cleaning the nozzle of the spray accessory (Optional)	EN-8
7.1.d - Pad replacement.....	EN-8
7.1.e - Orbiting group disassembly	EN-8
TROUBLESHOOTING	EN-9
WIRING DIAGRAM	EN-10

1.1 TECHNICAL CHARACTERISTICS

	U10		U10 SPRAY		U13
Brush motor power	1000 W				1300 W
Voltage	220 - 240 V~		110 V~		220 - 240 V~
Frequency	50 Hz	60 Hz	50 Hz	60 Hz	50 Hz
Oscillations per minute	n.1500	n.1800	n.1500	n.1800	n.1500
Working width - ø brushes	mm 430				
Brush pressure	44,3 g/cm ²		31,5 g/cm ²		48,2 g/cm ²
Motor passage height	270 mm WITH PAD H=25 mm				285 mm WITH PAD H=25 mm
Dry suction socket	YES				
Noise emission	59.5 dB(A)				
Vibration level	< 2.5 m/s ²				
Drive	DIRECT				
Cable length	12 m				
Weight (without accessories)	68 kg		58,5 kg		71,5 kg
Size	mm 730X450X1200				

1.2 INTRODUCTION



DANGER:

Before using the appliance, read the accompanying “**SINGLE DISC SAFETY WARNINGS**” booklet carefully.

This manual forms an integral part of the machine itself. It must therefore be kept in a safe place where it is accessible to all users (operators and maintenance personnel) throughout the life of the machine until it is scrapped.

1.3 - INTENDED USE OF THE MACHINE



WARNING:

This machine is for indoor use only.



DANGER:

Any other use releases the manufacturer from liability for harm to persons and/or property and invalidates any warranty condition.

This machine is intended for commercial use, for example in hotels, schools, hospitals, factories, shops, offices and rental businesses.

The machine has been designed and built: for professional use, for cleaning floors and carpets, for polishing floors, for sanding floors (e.g. parquet and uneven surfaces).

1.4 - NON-INTENDED USE OF THE MACHINE



WARNING:

The machine is not intended for outdoor use.



DANGER:

- do not wash floors with water above 50 °C;
- do not use diesel/petrol or corrosive detergents to wash floors;
- do not wash and suck up corrosive, flammable or explosive liquids, even if diluted.

2.1 UNPACKING (Figs. 1-2-3-4)

- Upon the machine delivery, remove the external packing and then cut the holders (1) (Fig.1). Raise the handle (2) by pulling the unlocking handle (3) (Fig.2);
- Lift the wheels (4) by leveraging the handle (2), rotate the machine and lay the wheels on the ground (Fig. 3);
- Lift the machine body (5) by leveraging the handle (2) and move the machine (Fig. 4).

2.2 COMPONENT ASSEMBLY

2.2.a - Pad assembly (Figs. 5/7)

- Tilt the head (6) of the machine; with one hand grip the handle (7) and at the same time push the machine backward.
- Mount the pad (8) on the pad holder (9) (Fig. 6).
- Make sure the outer perimeter of the pad (8) corresponds with the outer perimeter of the pad holder (9) and then lock it on the pad holder's teeth pressing down with your fingers (Fig. 7).



WARNING:

Use only pads supplied by the manufacturer for the specific machine model. Using other types of pads can compromise the safety of the machine.

2.1.b - Assembling the tank (optional) (Figs. 8-14)

- Loosen the knob (10) on the upper support (11) of the handle (Fig. 8).
- Make sure that the lower support (12) rests on the base of the handle joint (Fig. 11).
- Screw the chain (13) onto the top of the tank (14) (Fig. 9).
- Connect the tube (15) into the fitting (16) at the bottom of the tank (14) (Fig. 10).

- Place the tank (14) on the lower support (12), by aligning the tank slots (17) with the specific support guides (18) (Fig. 11).
- Press the tank (14) so that the slots are against the end stops on the lower support (12) guides.
- Lower the upper support (11) and attach its coupling to the coupling tab (19) on top of the tank (14) (Fig. 12).
- Tighten the knob (10) on the upper support (11) of the handle (Fig. 12).
- Connect the tube (20) fitting (15) to the hole on the machine body (Fig. 13).
- Attach the chain (13) to the hook of the water supply lever (30) (Fig. 14).

2.2.c - Electrical spray accessory assembly (Optional)



CAUTION:

The optional equipment may exclusively be assembled by a specialized technician following the assembly instructions that accompany the accessory.

2.2.d - Brush assembly (optional) (Fig. 15)

- Unscrew the four wing knobs (22) and remove the pad driver (23).
- Tighten the desired brush (24) in place of the driver with the wing knobs (22). Make sure to firmly tighten the wing knobs using pliers.

2.2.e - Filling the electrical spray tank (optional) (Fig. 16)

- Unscrew the tank (25) and remove it.
- Fill it with water and polishing wax. For dosing, refer to the instructions provided by the manufacturer of the polishing wax.
- Insert the suction tube (26) into the tank (25) and fully tighten.

2.2.f - Electrical connection

- Connect the machine power cable to a mains socket whose characteristics correspond to those shown on the machine's technical data plate.



WARNING:

- **Unwind the power cable completely before turning on the appliance.**
- **Use an extension cord only if in perfect condition and make sure the diameter is appropriate for the power of the appliance.**
- **Never allow the power cable to slide over sharp edges and do not crush it.**
- **The socket should be easily accessible.**
- **Make sure the electrical cable is not damaged.**

3.1 KNOWLEDGE OF THE MACHINE (Figs. 17-18)

- 4) Wheels
- 3) Handle tilt lever
- 5) Machine body
- 7) Head lifting and machine movement handle
- 11-12) Supports
- 27) Guide handle
- 28) Electric control box
- 29) Brush rotation start levers (on-off)
- 30) Water supply adjustment lever
- 31) Power cable
- 32) Brush rotation lever release button
- 33) Wax spray start button (optional)
- 34) Pusher tags

4.1 HANDLE TILT ADJUSTMENT (Fig. 19)



WARNING:

The handle position must be adjusted while the appliance is at a standstill.

- Pulling the lever (3) the handle position can be adjusted (27); when the lever is released, the handle is positioned and locked in the closest position required.



NOTE:

Adjust the handle to a comfortable position, depending on your height, in order to easily push the machine in straight paths.
Never start the machine without having tilted the handle correctly.

5.1 GUIDE HANDLE (Fig. 17)

- 1) **Pad rotation lever release button (32)**
Press the button (32) to release the pad rotation start levers (29).
- 2) **Pad rotation start levers (29)**
Pulling the pad rotation levers (29) enables pad rotation.
When the levers (29) are released, pad rotation stops and the machine stops automatically.
The levers (29) should be kept pulled to achieve continuous machine operation.
- 3) **Water supply adjustment lever (30) (in the presence of an optional tank)**
Pulling the lever (30) activates the water supply for washing the floor.
When the lever is released (30) the water supply is interrupted.
- 4) **Polishing liquid spray button (optional) (33)**
When the button is pressed and held down, the polishing liquid spray is activated; if the button is released, the spray stops.



NOTE:

The spray works even when the pad is not rotating.

6.1 OPERATION

6.1.a - Checks to be performed before use

- If the electrical spray accessory is mounted (optional), check that it contains enough polishing liquid for the working phase and that the nozzle is properly connected and adjusted.
- Check the condition of the pad.
If worn, replace it.
- Check that the appliance, particularly the mains cable, is not damaged in any way that might compromise correct machine operation or the operator's safety.

6.1.b - Additional weights assembly (Fig. 20)

- If there's the need to increase the ground pressure, it is possible to assemble the additional weights Kit, which weighs 6,5 kg, or the double additional weights Kit which weighs 13 kg.
- Position the front weight (35) and the rear one (36) and fix them with the supplied knobs (37); short knob for the single additional weights kit, long knob for the double additional weights kit.
- It is advised to mount the pair of weights (front + rear) instead of a single weight in order to avoid abnormal vibrations.



NOTE:

While mounting the rear weight (36), check the correct position of the water hose passage hole (38).

6.1.c - Starting the machine (Fig. 17)



WARNING:

**Do not start the machine if it is tilted.
Do not start the machine if the pad is not correctly mounted.**



DANGER:

Ensure your hands are dry before using the appliance.

- Pull the lever up (3) and lower the handle until it reaches the height desired.
- Press the button (32) to release the pad rotation start levers (29).
- Pulling the levers (29) starts the machine.
- When both levers (29) are released, the machine stops.



WARNING:

Never wrap the network cable around the operator the operator's neck or the machine body.

6.1.d - Using the machine (Fig. 17)

- After starting the machine, begin cleaning by keeping the levers (29) pressed, thus keeping the machine running and brush rotation active.



DANGER:

During operation, avoid passing over the power cable with the machine: this could cause serious damage and dangerous situations!



NOTE:

Using the machine in a fixed position with the pad rotation enabled for a prolonged period of time can cause damage to the floor.



NOTE:

When the levers (29) are released, pad rotation stops and the machine turns off

6.1.e - Use with overturned handle (Fig. 21)

- Partially raise the handle (2) and unlock the pusher tags (34) with one foot.
- Slowly rotate the handle (2) until it automatically locks through the pusher tags (34).
- Adjust the handle (2) height through the lever (3) depending on your needs.

6.1.f – End of use and shutdown (Fig. 17-22-23).

- Release the levers (29) to stop pad rotation and turn off the machine (Fig. 17).
- Put the handle in an upright position.
- Remove the tank (Optional), empty the solution and clean the nozzle as indicated in the maintenance paragraph.



WARNING:

Do not leave the machine stopped if the pad is mounted and not raised in order to prevent them from being damaged.

- Unplug the power cable from the socket and wrap it around the cable reel supports.
- Roll up the cable on the supports (11) (12) (Fig. 22).
- To remove the cable from the supports, turn the hooks (11) (12) inward and remove the cable without necessarily unwinding it (Fig. 23).

6.1.g - Transport (Fig.24)

Making sure that the mains plug is disconnected and the handle is in an upright position, lift the machine body by turning the handle downwards.

The machine can then be transported on the wheels.

If it is necessary to lift the machine for loading on trucks or for climbing stairs, proceed as follows:

- Release the two pusher tags (34) and, through the handle (7), slightly move the head so that the two pusher tags hook correctly.
- Two persons must raise the machine: one on the guide handle (2) and the other through the handle (7).

7.1 MAINTENANCE AND CLEANING



WARNING:

For information and warnings relating to maintenance or cleaning, follow what is described in the “Safety warnings for single disc” manual, accompanying this document.

OPERATIONS TO BE CARRIED OUT DAILY

7.1.a - Cleaning the machine

Clean the machine with a damp cloth and then wipe it with a clean, dry cloth to prevent the formation of scale due to the effect of chemicals.



WARNING:

Do not use solvents, acids or corrosive substances for cleaning the machine. If the pad is dirty, wash it at a maximum temperature of 60 °.

7.1.b - Emptying and cleaning the water tank (optional)



WARNING:

Once you have finished washing, you must drain and clean the water tank to prevent deposits or scale.

To empty the water tank, release it from its supports.

7.1.c - Cleaning the nozzle of the spray accessory (Optional) (Figs. 16-17).



WARNING:

Once you have finished polishing, you must drain and clean the water tank to prevent deposits or scaling and you must clean the nozzle.

- Remove the tank (25) (Fig. 16), empty the solution, rinse it and refill it with water.
- Position yourself with the machine near a discharge drain and press the button (33) (Fig. 17) until the tank is empty.

OPERATIONS TO BE CARRIED OUT WHEN NECESSARY

7.1.d - Pad replacement

The pad must be replaced when it is worn and its thickness is less than 10 mm; see the "Pad Assembly" paragraph for replacement instructions.

7.1.e - Orbiting group disassembly (Figs. 25-26-27-28-29)

- Unscrew the four wing knobs (22) and remove the disc (39) and the driver disc (9).
- Unscrew the hexagon head screw (40) by blocking the rotation through a contrast surface (41)
- Unscrew the two screws (42) and remove the cover (43).
- Tighten the supplied M12 Allen screw (44), to extract the orbiting group (45); block the rotation using a contrast surface if necessary.



NOTE:

Reassemble everything proceeding in reverse order to the disassembly operations: when re-assembling the driver disc (9), centre the two plugs (46) of the orbiting group (45) on the holes (47) of the driver disc.

TROUBLESHOOTING

PROBLEM	CAUSE	SOLUTION
Although the lever release button and brush rotation levers are pressed at the same time, the machine does not start.	The appliance is unplugged.	Plug the appliance in.
The pad holder does not rotate.	The brush/pad holder rotation lever is not pressed.	Press the lever.
	Presence of foreign bodies.	Remove any foreign bodies stuck in the appliance.
No water is released	The tank is empty.	Fill the tank.
	Water supply lever not pressed.	Press the lever.
Polishing liquid is not released.	The tank is empty.	Fill the tank.
	Button not pressed.	Press the button.
Insufficient floor cleaning	Pad or chemical product not suitable.	Use a pad or chemical product that is appropriate to the type of floor to be polished.
	Pad worn.	Replace the pad.
The machine operates erratically or vibrates heavily.	Check that the pad is perfectly centred in the pad holder.	Replace the pad, centring it correctly in the pad holder.
	Pad not suited to floor type.	Use a pad suited to the floor surface.

DEALER

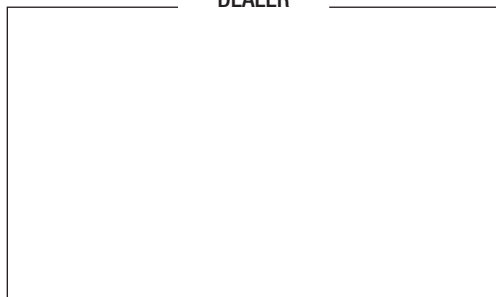

Riello Cleaning Machines S.p.A.

Registered Office

Via Enrico Fermi, 43 - 37136 Verona (VR) - Italy

Headquarters

Via Circonvallazione, 5 - 27020 Dorno (PV) - Italy

P. +39 0382 848811 - F. +39 0382 84668 - M. info@riellocm.com



ghibli.com - wirbel.it

