

HOT WATER PRESSURE WASHER GPW 120.9 SP H



EN INSTRUCTION MANUAL - USE - MAINTENANCE

(TRANSLATION OF THE ORIGINAL INSTRUCTIONS)

Attention: Do not use the appliance until you have read the operating and maintenance manuals.

CE

49.0390.00
ed. 05/2026



- **Model:** **GPW 120.9 SP H**
- **Serial number:**
- **Year of manufacture:**

**THIS MANUAL IS INTENDED FOR ALL GPW 120.9 SP
H MODELS**

NOTES FOR THE CONSULTATIONS OF THE MANUAL

This manual contains the information and anything else considered necessary for the knowledge, good use and normal maintenance of the GPW 120.9 SP H hot water pressure washer, hereinafter also referred to as machine or pressure washer, manufactured by the constructor hereinafter also referred to as Manufacturer.

This manual does not provide a complete description of the various parts nor a detailed description of their operation; the user will find that it is normally useful to know what to do in order to use the machine safely and keep it in good condition.

On the observance and fulfilment of the above, together with careful maintenance, depend the smooth running, the duration and the economy of operation of the machine.

This manual is supplied in single copy with the purchase of the machine. In the event that the Customer needs more copies, it must be requested from the Manufacturer, specifying the model and serial number of the machine in question (the information is on the nameplate).

This manual was written in Italian by the Manufacturer's Technical Department and is translated into all the languages of the European Community countries where the machine is sold. In the event of disputes or incorrect translation and interpretation, the manual in the language of the machine Manufacturer's country applies.

The use of the machine question necessarily requires that the User is a person with good professional skills and work experience with similar machines. If this is not the case, it is essential that the user attends a course on how to use the machine at the manufacturer's premises or at a dealer's or, in any case, by personnel qualified by the manufacturer.

This manual is an integral part of the machine and, therefore, must be stored so that it is always available for consultation, in a protected and dry place away from direct sunlight.

Throughout this manual there are several safety guidelines that aim to make using the machine easier and safer. To facilitate understanding they have been divided into:

- **WARNING:** this term identifies events that may compromise the integrity of the machine.
- **CAUTION:** this term identifies events that may compromise the safety of operators. In some cases they are shown in bold.
- **NOTE:** this term identifies general information on the machine and important information for a successful production cycle.

ATTENTION



ALL REQUESTS OR ORDERS FOR ACCESSORIES AND/OR SPARE PARTS FOR THE MACHINE SHOULD BE FORWARDED TO THE MANUFACTURER'S SALES OFFICES.

The manufacturer reserves the right to make changes to the dimensions, shapes and characteristics of the machine at any time and without prior notice.

ATTENTION



The manual must be kept close to the operator's station and re-read periodically. THE MANUAL MUST ALWAYS ACCOMPANY THE MACHINE, EVEN IN THE EVENT OF RESALE.

MAIN WARNINGS FOR MACHINE USE



It is mandatory to read this Use and Maintenance Instruction Manual before carrying out any work on the machine: its initial operation by unqualified persons could cause serious injuries to people and damage to property.

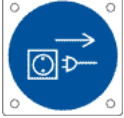

All maintenance, adjustment and replacement operations described in this Use and Maintenance Instruction Manual must only be carried out after the machine has been stopped. Do not work on the machine before stopping the moving parts that make it up.



The keys for opening the guards must be kept by the person in charge of the machine. Leaving the key inserted in a lock may cause a danger that an unauthorised person will come into contact with hazardous moving parts.



The operations that require direct contact with machine parts that heat up during processing, such as adjustment, assembly and replacement, must only be carried out using protective gloves to avoid any risk of accident.



The guards have been fitted by the Manufacturer in order to safeguard the operator's safety. During operation the guards must not be removed for any reason.



It is forbidden to tamper with, alter or modify, even partially, the machine, the equipment of the command and control system and the relative devices for interfacing with the operator, as well as the protections provided for the safety of persons.



It is extremely important that no unauthorised person passes through the working area of the machine or, worse still, intervenes on a component of the machine during its operation, in order to avoid possible accidents.



Before starting the MACHINE make sure that all protective devices are in place and fully functional.



Smoking is strictly forbidden in the vicinity of the machine during refuelling and in all phases of work, maintenance and cleaning of the machine.



Before carrying out any adjustment, maintenance and/or replacement operations, the operator is required to wait a certain period from when the machine is stopped: this period, in fact, is necessary to let the areas that heat up during normal operation cool down. It is always necessary to pay utmost attention to all areas of the machine where there is a hazard of burns, due to contact with parts that heat up during the operating cycle.



When carrying out adjustment, maintenance and/or replacement operations within the working area of the machine, pay the utmost attention to all potentially hazardous elements.



Be extremely careful in areas of the machine where there is a risk of contact with moving parts, in order to avoid crushing/dragging of the upper limbs.



During lifting and transport operations, special lifting devices and ropes or chains with a load capacity greater than the sum of their own weight and that of the item to be lifted must be used.

NOTE

IN THE NEXT CHAPTERS, AT THE END OF THE PARAGRAPH, SUITABLE “CAUTION” NOTICES WILL BE LISTED REGARDING THE SPECIFIC RISKS APPLICABLE TO THE CHAPTER. THIS DOES NOT EXEMPT YOU, HOWEVER, FROM CONSIDERING ALL THE MAIN WARNINGS DESCRIBED ABOVE APPLICABLE.

IMPORTANT NOTE PLEASE NOTE THAT THE USER IS REQUIRED, IN ACCORDANCE WITH ITALIAN LEGISLATIVE DECREE NO. 81/2008, TO UNDERTAKE A PROPER ANALYSIS OF THE RISKS RELATING TO THE MACHINE / PERSONNEL OPERATIONS UPON COMMISSIONING THE MACHINERY IN THE WORKPLACE.

NOTE

ALL FORESEEABLE ACTIVITIES WITH THE MACHINE, WHETHER FOR TECHNICAL WORK OR PRODUCTION USE, HAVE BEEN CAREFULLY ANALYSED FROM THE INITIAL DESIGN STAGE THROUGH TO THE DRAFTING OF THIS MANUAL. DESPITE THIS, RESIDUAL HAZARDS MAY EMERGE OVER TIME. IN PARTICULAR, HAZARDS MAY EMERGE THAT, ALTHOUGH IDENTIFIED, CANNOT BE ELIMINATED OR SUFFICIENTLY REDUCED BY DESIGN AND AGAINST WHICH SAFEGUARDS ARE NOT FULLY EFFECTIVE.

THE OPERATOR MUST THEREFORE TAKE SERIOUSLY THE HAZARD SIGNS ON THE MACHINE AND EVERYTHING IN THE MANUAL.

INSTRUCTION MANUAL TABLE OF CONTENTS

CHAPTER 1 - General information on the instruction manual..... 8

 1.1 Introduction 8

 1.2 Standards of reference 8

 1.3 Compliance with legislation..... 9

 1.4 Declaration of absence of harmful substances 9

 1.5 Purpose of the document..... 9

 1.6 Marking data and machine identification plate 9

 1.7 Use and storage of the Manual..... 10

 1.8 Documents accompanying this Manual 10

 1.9 User information 10

 1.9.1 Definition of Warranty 11

 1.9.2 Target audience 11

 1.9.3 Personnel training..... 11

 1.9.4 How to request technical assistance..... 11

 1.10 Terminology used 11

CHAPTER 2 - General machine description..... 13

 2.1 Description of the machine elements 15

 2.2 Construction Technology 17

CHAPTER 3 - Machine safety and protection..... 19

 3.1 Safety rules for electrical risk..... 19

 3.2 Safety rules for thermal risk (burns)..... 19

 3.4 Safety standards for environmental risk 20

 3.4.1 Safety signs and stickers on the machine 20

CHAPTER 4 - Residual risks..... 22

CHAPTER 5 - Personal protective equipment..... 24

CHAPTER 6 - Intended and unintended use..... 24

 6.1 Use in closed environments 25

 6.2 Use in locations subject to wind or strong air currents 25

 6.3 Contraindication and hazards due to unintended or misuse 26

CHAPTER 7 - Technical Data 27

 7.1 Environmental requirements 27

 7.2 Dimensions and technical data 27

CHAPTER 8 - Commissioning the machine..... 28

 8.1 Preventive checks after receipt..... 28

 8.2 Checking the machine status 28

CHAPTER 9 - Handling and installation of the machine..... 29

 9.1 Preliminary operations 29

 9.2 Lifting 29

 9.3 Transport 29

9.4 Free spaces of respect	29
CHAPTER 10 - Connections to external energy sources	30
10.1 Electrical connection	30
10.2 Water connection	31
CHAPTER 11 - Control parts	32
11.1 Control station.....	32
11.1.1 touch screen control panel.....	33
CHAPTER 12 - Preparing the machine for use	34
CHAPTER 13 - USE OF THE MACHINE	36
13.1 Description of the operating cycle	36
13.1.1 Cold water operation	36
13.1.2 Hot water operation	37
13.1.3 Use with chemical product	39
13.2 Contraindications to using the machine	41
CHAPTER 14 - Maintenance	41
14.1 Pressure washer cleaning	42
14.2 maintenance intervals	42
14.3 Pump lubrication	42
14.4 Adjusting the ignition electrodes	43
14.4.1 Control of the height in relation to the plane of the diesel nozzle head.....	Errore. Il segnalibro non è definito.
14.4.2 Electrode distance control	Errore. Il segnalibro non è definito.
14.4.3 Checking the distance between the electrodes and the centre of the diesel nozzle head.....	Errore. Il segnalibro non è definito.
14.5 Troubleshooting.....	44
CHAPTER 15 - Disposal.....	47
15.1 Pressure washer disposal (demolition of the machine)	47
15.2 Disposal of consumables or materials subject to wear and tear.....	47
15.3 . Disposal of packaging	47
CHAPTER 16 - Temporary decommissioning of the pressure washer.....	48
CHAPTER 17 - Sound Emission.....	48
CHAPTER 18 - Hand-arm vibrations.....	49
CHAPTER 19 - SUMMARY OF THE MAIN WARNINGS	50
CHAPTER 20 - SPARE PARTS.....	50
20.1 Ordering rules	50
20.2 Personal data.....	50
ANNEXES
A - ELECTRICAL SYSTEM DIAGRAM
B - HYDRAULIC SYSTEM DIAGRAM

CHAPTER 1 - GENERAL INFORMATION ON THE INSTRUCTION MANUAL

1.1 INTRODUCTION

This manual will help you get to know your machine and use it correctly, so please read it carefully before using it. Each machine is sold with its own Use and Maintenance Manual. The user is responsible for the management of this manual throughout the life of the machine and will only dispose of it if it is destroyed.

The manufacturer shall not be liable for any tampering with this manual or for any changes made to the machine by the user after delivery which are not covered in this document.

The Manufacturer reserves the intellectual property rights to this Manual and prohibits its dissemination in whole or in part, in any form whatsoever (print, photocopy, microfilm, or other means) and also its processing, reproduction or dissemination by electronic systems, to legal or natural persons without its approval and registration.

1.2 STANDARDS OF REFERENCE

The indications contained in the documents have been used in drafting the Manual:

- **DIRECTIVE 2006/42/EC OF 29/12/2009 - ITALIAN LEGISLATIVE DECREES 17 OF 2010** concerning:
WORK SAFETY AND HYGIENE - Machinery Directive.
- **DIRECTIVE 2014/35/EC** on the harmonization of the laws of Member States relating to electrical equipment designed for use within certain voltage limits.
- **DIRECTIVE 2014/30/EC** concerning:
ENVIRONMENT - Radiation pollution - Radio frequencies and magnetic fields.
- **UNI EN ISO 13857 :MARCH 2008** concerning:
Safety of machinery - Safety distances to prevent reaching hazardous areas with upper and lower limbs.
- **UNI EN 981 : 2009** concerning:
Safety of machinery - Systems of auditory and visual hazard and information signals.
- **UNI EN ISO 13850: 2015** concerning:
Safety of machinery - Emergency stop - Design principles.
- **UNI EN 12100 :2010** concerning:
Machinery safety - General principles of design - Risk assessment and risk reduction.
- **UNI EN ISO 14119 :2013** concerning:
Safety of machinery - Interlocking devices associated with guards - Principles of design and selection.
- **UNI EN ISO 60335-1:2014** concerning:
Safety of household and similar electrical appliances - Part 1: General part.
- **UNI EN ISO 60335-2-79 :2012** concerning:
Safety of household and similar electrical appliances - Part 2: Special regulations for pressure washers and steam cleaning appliances.

1.3 COMPLIANCE WITH LEGISLATION

In addition to the rules of this Manual, the specific legal provisions in the field of accident prevention at work must be observed.

1.4 DECLARATION OF ABSENCE OF HARMFUL SUBSTANCES

We hereby declare that our products, including hot-melt adhesive used during processing the machine, are produced with materials that comply with the limits established by the regulations in force on the protection of health and the environment and do not contain substances classified as SVHC (Substance of Very High Concern) in accordance with EC 1907/2006 regulation (REACH, i.e. *Registration, Evaluation, Authorisation and Restriction of Chemical substances*).

Although the above mentioned substances are not employed in processing cycles of raw materials and our products, their presence cannot however be ruled out in the order of ppm (parts per million), due to the micro-pollution of the raw materials.

1.5 PURPOSE OF THE DOCUMENT

The purpose of this manual is to provide the user with the indications and information to be followed scrupulously for the correct use of the machine and for the protection and safety of the operator called upon to interact with it.

For this reason, the User is invited to:

- make this document available in the workplace and explain it to all operators,
- passing on the manual to subsequent owners of the machine.

1.6 MARKING DATA AND MACHINE IDENTIFICATION PLATE

The nameplate on the machine shows the manufacturer's data, the model, the serial number and the year of construction.

For any communication regarding the machine (problems encountered, warranty work, spare parts, etc.) always refer to this and the data contained therein.

In addition, any warning signs attached to the machine must not be removed for any reason whatsoever and must be strictly observed.



RIELLO		  LwA 97 LpA 84,4
CLEANING MACHINES Tel.0382848811- ITALY MADE IN ITALY 		
Codice/Code	91160042/4GPW	
Model	GPW 120.9 SP H	
Serial Nr. / Numero di serie	Prova	
Lot production / Lotto	01/99	
Working pressure	12 MPa	1740 psi
Pressione d'esercizio		120 bar
Feed press. Min./Max. 0,4/1 Mpa	58/ 145	psi
Press. di Aliment. Min. / Max	4 / 10	bar
Max feeding temp.	104 °F	
Temp. Max Aliment.	40 °C	
Water output max. temp.	212 °F	
Temp. Max Uscita Acqua	100 °C	
Motor horsepower/Potenza effett.	2.7 Kw	
Numero di Giri/ R.P.M.	1450 Rpm	
Frequency/Frequenza	50 Hz	
Voltage / Tensione	230V 1~+T	
Max pressure	12 MPa	1740 psi
Pressione Massima		120 bar
Delivery	2,38 Gpm	
Portata	9 dm3/min - l/min	
Boiler Output/Potenza Caldaia	53 Kw/h	
Peso/Weight	80 Kg	



FIGURE 1 SECTION 1.6 - Marking data and machine identification plate

1.7 USE AND STORAGE OF THE MANUAL

This manual is intended for the user of the machine, those responsible for moving, installing, using, monitoring and final dismantling.

The manual serves to indicate the intended use of the machine in accordance with the design assumptions and technical characteristics; it provides instructions for moving, appropriate and safe installation, assembly, adjustment and use; it provides information to direct maintenance work, facilitates the ordering of spare parts and provides information about any residual risks.

In particular, the following information must be constantly available for consultation:

- Conditions of use envisaged for the machine;
- Workstation occupied by the operator;
- Instructions on:
commissioning, operation, transport, installation, assembly and disassembly, adjustment, maintenance and repair work, any training instructions;

The manual is considered to be an integral part of the machine and must be kept in good condition until it is finally scrapped.

The manual must be stored in a protected, dry place, protected from sunlight and must always be available for consultation near the machine.

1.8 DOCUMENTS ACCOMPANYING THIS MANUAL

The machine is supplied complete with:

- EC' declaration of conformity of the machine;
- Instruction manual for the installation, use and maintenance of the machine

1.9 USER INFORMATION

This manual reflects the current state of the art of the machine and cannot be considered to be a guide inadequate only because it has been updated on the basis of new experience; the manufacturer reserves the right to update production and manuals, without being obliged to update previous production and manuals.

The characteristics of the materials may be changed at any time, according to technical development, without prior notice.

The manufacturer is relieved of any responsibility in the event that the machine is used:

- misuse;

- use by untrained personnel;
- use contrary to the provisions of this Manual;
- use contrary to applicable laws and regulations;
- use with primary power failure;
- use with serious deficiencies in planned maintenance;
- use with modifications or interventions not explicitly authorised by a written note from the manufacturer;
- use with non-original spare parts or not specifically defined by model;
- use with total or partial disregard of the instructions contained in this Manual.

1.9.1 DEFINITION OF WARRANTY

The machine is subject to warranty in accordance with the agreed contractual terms which form an integral part of the order or regulations in force, in all cases for a maximum period of twelve (12) months from the date of dispatch from the factory. The guarantee only covers faults that may be due to mechanical or assembly defects. The warranty does not cover wear parts and electrical parts.

The general sales warranty is void in the event of:

- poor conservation;
- inexperience of use;
- exceeding performance limits;
- excessive mechanical and/or electrical and pneumatic stress;
- improper use of the machine, failure to observe the rules of use;
- use of non-original spare parts, i.e. not sold directly by the manufacturer or authorised dealer;
- modifications to the machine or maintenance work not carried out by personnel recommended by the manufacturer or the dealer.

Any requests for further copies of this document must be settled with a purchase order sent to the Manufacturer.

1.9.2 TARGET AUDIENCE

This manual is the basic tool for personnel who, in various capacities, deal with the machine in various tasks, such as:

- Transport and machine handling workers.
- Pressure washer operators.
- Maintenance operators.
- Final demolition workers.

Before proceeding with the various operations, the persons listed above must have carefully read and memorised this manual.

1.9.3 PERSONNEL TRAINING

Ordinary use does not require the use of particularly specialised personnel, provided that they are adequately trained and instructed in the operations to be carried out, are familiar with this manual and are aware of the general safety regulations.

Please follow the instructions carefully, for your own safety, for the safety of others, for the protection of your machine and for the protection of the environment.

1.9.4 HOW TO REQUEST TECHNICAL ASSISTANCE

The constructor is at the complete disposal of its customers to ensure prompt and accurate technical assistance and anything else that may be useful for the best operation and maximum yield from the machine. For each service request, the data on the identification plate and the type of fault detected must be communicated.

The costs of disassembly and assembly and of transport or packaging of the parts to be repaired or replaced shall be borne by the Customer.

1.10 TERMINOLOGY USED

To complete the description of the various levels of danger, specific situations and definitions which may directly affect the machine and/or persons are described below.

- **USER:** It is the person, or the body or company, who has purchased or rented the machine and who intends to use it for the purposes intended.
- **TRAINING:** Phase enabling the operator to learn the necessary knowledge of the machine to carry out the production activity independently, correctly and safely.
- **WORKING AREA:** Any area in which operators can carry out machine operations.
- **DANGER ZONE:** Any area inside and/or around machinery where the presence of an exposed person constitutes a risk to the safety and health of that person.
- **RESIDUAL RISK:** This is the risk that remains, especially during maintenance, installation and cleaning, even after the application of design and construction safety measures, safety devices and deterrents.
- **EXPOSED PERSON:** Any person who is wholly or partly in a hazardous area.
- **OPERATOR:** The person(s) in charge of installing, operating, adjusting, maintaining, cleaning, repairing and transporting the machine.
- **ROUTINE MAINTENANCE:** Combination of actions and technical checks, to be carried out periodically as specified by the manufacturer, aimed at maintaining the machine in conditions of maximum efficiency and safety.
- **EXTRAORDINARY MAINTENANCE:** Interventions required in the event of anomalies or faults, or to maintain maximum functionality and efficiency of the machine. Such interventions must be carried out by specialised personnel.
- **SPECIALISED PERSONNEL:** These are the people who are trained and authorised to carry out repair or maintenance work requiring special knowledge of the machine and who are able to recognise the hazards arising from incorrect or improper use of the machine.

CHAPTER 2 - GENERAL MACHINE DESCRIPTION

The GPW 120.9 SP H hot water pressure washer referred to in this manual is primarily designed to pump water at a pressure of 120 bar.

The hot water pressure washer is intended exclusively for cleaning and washing with hot or cold water of objects or surfaces that are suitable for mechanical treatment by the high-pressure water jet and the possible chemical action of detergents.

In the case of hot water cleaning, the water is heated inside a boiler equipped with heating coil, thanks to a burner fed by diesel oil.

The water pressure is provided by a piston pump driven by an electric engine, powered at different voltages and number of phases (depending on the model).

The cleaning agents to be used must be liquid-based and not powdered and must be biodegradable, in accordance with current regulations.

Ref. A: The boiler is also equipped with a photoresistor that monitors the presence of the flame in the boiler, communicating with the electronic board in the event of a malfunction (and thus interrupting any diesel fuel supply).

Ref. B: In addition to the above-mentioned system, there is a glass in the nut, also located on the upper part, for visual verification of the presence of the flame.

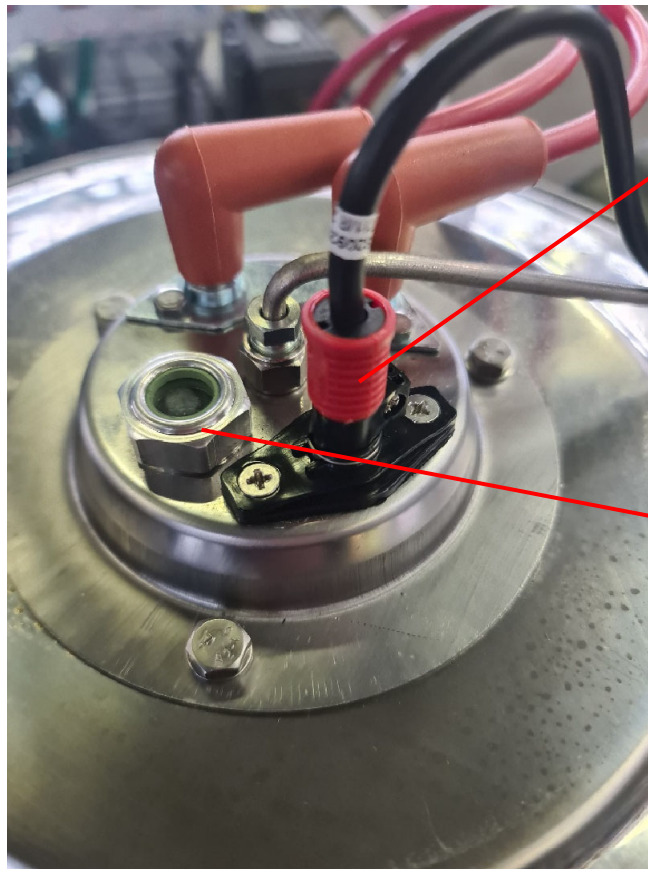

Rif.A

Rif.B



ATTENTION



During operation, no-one other than the operators in charge must stand near the machine or, worse still, intervene on it.



The protections have been designed by the manufacturer in order to safeguard the safety of the operators while carrying out their tasks. During operation, the guards must not be removed for any reason.

2.1 DESCRIPTION OF THE MACHINE ELEMENTS

The pressure washer consists of the following main components (see figures in this section):

1. Steel body
 2. Steel supporting frame
 3. 24 litre diesel tank
 5. 3-piston ceramic pump with connecting rod/crank system and brass head. Pressure regulation and built-in detergent suction.
 6. Electric engine with thermal protection. 230 V / 50 Hz Standard (60 Hz on request)
 7. High efficiency vertical boiler with refractory cement bottom and stainless steel head. (with photocell for flame control).
 8. Pressure gauge
 9. Thermostat
 10. Safety valve
 11. 5 m electric cable.
 12. Gun
 13. Wand
 14. A.P. pipe 10 m
- Diesel, water and detergent filters.

Figura 1.4



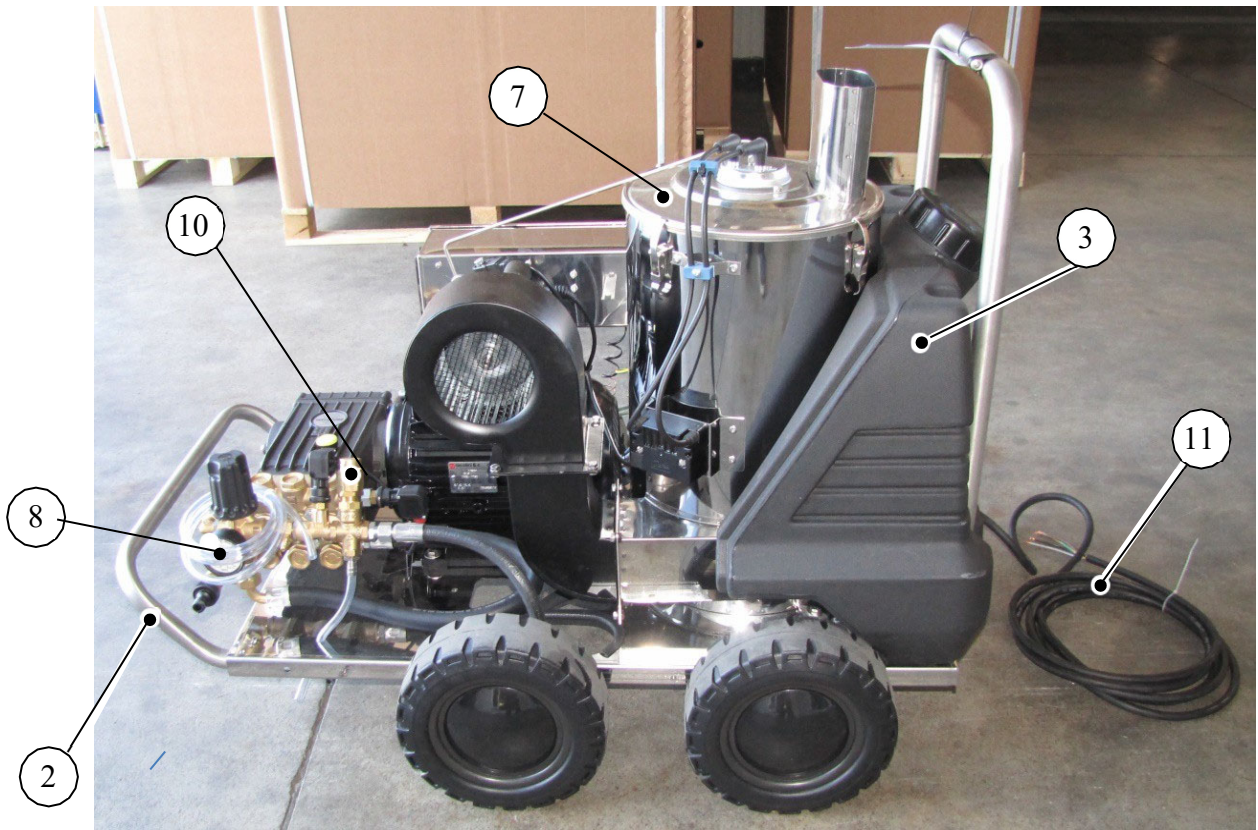

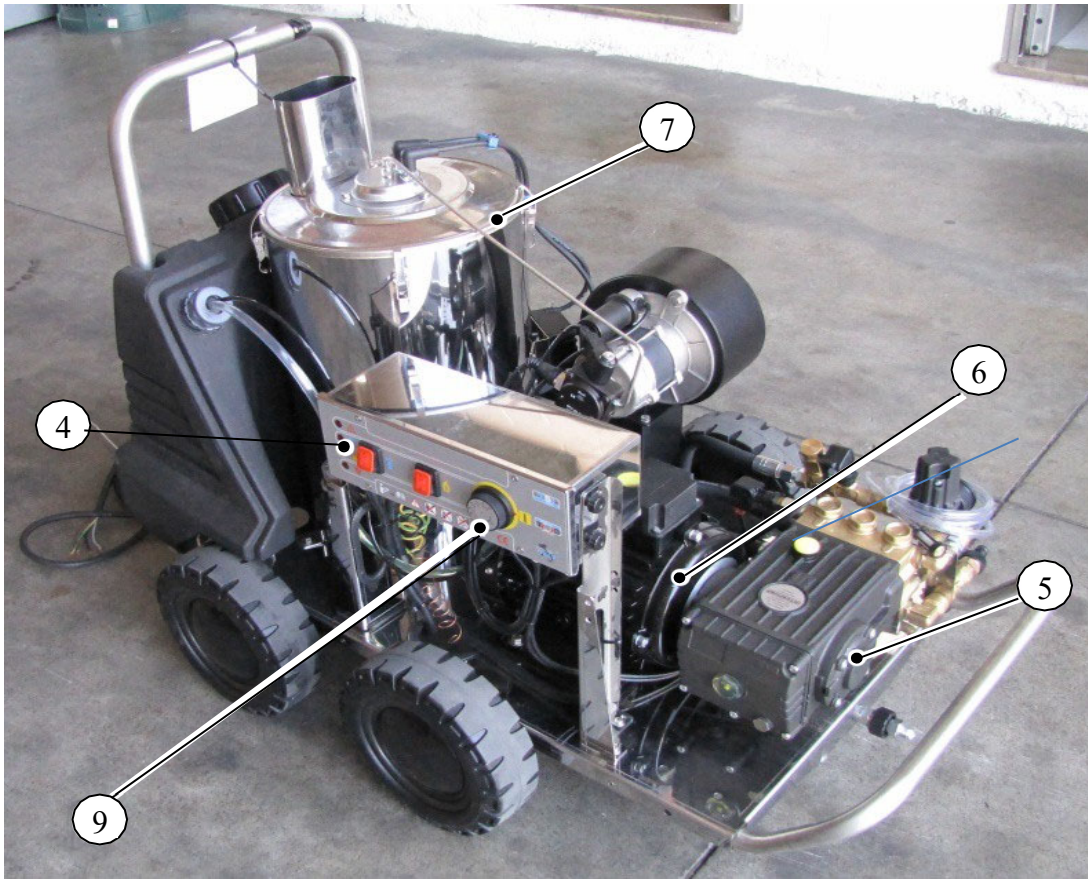

2.2 CONSTRUCTION TECHNOLOGY

The products are always up-to-date, both in design and technology, to make the use of high pressure washers safer, simpler and more reliable, both from the user's point of view and from the technical assistance point of view.

TDTs
Time Delayed Total Stop

TDTs control

- Timed total stop after 12 sec. on gun release
- Total stop of the machine, boiler electric motor and burner.

ATTENTION



During operation, no-one other than the operators in charge must stand near the machine or, worse still, intervene on it.



The protections have been designed by the manufacturer in order to safeguard the safety of the operators while carrying out their tasks. During operation, the guards must not be removed for any reason.



Before intervening in the working area of the machine (for maintenance, adjustment or replacement operations), the operator must wait a certain period necessary to bring the heated elements back to a temperature close to the ambient temperature. The operations must be carried out using protective gloves in order to avoid any risk of injury (heater).



Use protective gloves in order to avoid any type of injury due to the hazardous elements of the machine.

CHAPTER 3 - MACHINE SAFETY AND PROTECTION

3.1 SAFETY RULES FOR ELECTRICAL RISK

- Do not use the machine outdoors in the rain.
- If, despite all the precautions taken, the cable is damaged, do not carry out temporary repairs. A new cable is much cheaper than repairing the damage caused by a possible electric shock, not to mention the danger that a defective cable would pose to people and animals.
- Do not carry out any maintenance while the plug is plugged into an electrical outlet.
- Take care not to hit the machine with water jets, as this could cause a short circuit
- If an extension cable is to be used for the electrical cable, ensure that the connection between the supplied cable and the extension cable is made in a stable manner and in accordance with current safety regulations.
- The plug and socket must be watertight.
- Do not use the electrical plug to switch the machine on or off; only use the appropriate switches.
- Keep the machine out of the reach of children and/or unauthorised persons and make sure that nobody can touch it when it is connected to the mains.
- It is strictly forbidden for the operator to carry out any operation with the machine if he is barefoot.
- Do not operate the machine with defective components.
- Do not use the machine in the presence of people on the working line.
- Do not direct the water jet at electrical sources....

3.2 SAFETY RULES FOR THERMAL RISK (BURNS)

- Do not put your hands in front of the wand; high-pressure nozzles can be extremely dangerous when used improperly.
- If the machine is used in petrol and filling stations or other dangerous places, the relevant safety regulations must be observed.
- Do not touch the engine, chimney, boiler or other parts when the machine is switched on or immediately after it is switched off.
- Diesel refuelling must only be carried out when the machine is switched off.
- Do not use fuels other than those specified by the manufacturer.
- When the work is completed, after stopping the machine, release the residual pressure in the delivery pipe and in the pump by operating the gun lever.
- It is strictly forbidden to carry out any work on the machine unless you are equipped with personal protective equipment (protective goggles, gloves, overalls, etc.) in accordance with current regulations.
- During the winter and in the event of frost, it is advisable to have antifreeze sucked in or empty the water in the internal circuits by closing the tap on the water mains and running the machine until it is completely drained.
- If the machine is left idle for a long period of time, limescale build-up may form on the valve seats and cause starting problems, so pay close attention to any abnormal noises and consult your local technical service.

3.3 SAFETY RULES FOR MECHANICAL RISK

- Do not put your hands in front of the wand; high-pressure nozzles can be extremely dangerous when used improperly
- When the work is completed, after stopping the machine, release the residual pressure in the delivery pipe and in the pump by operating the gun lever.
- Unwind the high-pressure hose completely before use.
- Lock the machine if fitted with wheels before using it once positioned.

3.4 SAFETY STANDARDS FOR ENVIRONMENTAL RISK

- It is strictly forbidden to wash engines in unsuitable spaces, this operation must only be carried out in places where, for environmental protection, a suitable oil separator is installed.



3.4.1 SAFETY SIGNS AND STICKERS ON THE MACHINE

REFERENCE	P1
DESCRIPTION	Safety pictogram for high temperature risk (yellow background).
HAZARD EXPLANATION	<ul style="list-style-type: none"> ▪ Generic HAZARD Do not remove safety devices for any reason. Always keep them in good condition. Ensure that all guards, covers and shrouds are properly in place, particularly after machine repairs. Have any damaged guards repaired immediately. ▪ Burn HAZARD Pay attention to high temperature surfaces. Stay away from hot surfaces such as boiler, chimney. ▪ HAZARD when refuelling Diesel fuel Avoid fuel drips in the chimney area and on the machine when refuelling.
IMAGE	

REFERENCE	P2
------------------	-----------

DESCRIPTION	<p>Pictograms on the control panel providing safety instructions on the risks involved in using the pressure jet</p>
HAZARD EXPLANATION	<ul style="list-style-type: none"> ▪ Generic HAZARD Read the manual before using the machine ▪ HAZARD of cutting, impact, abrasion, burns Do not direct the jet at people or animals Machine with fluid under pressure. When using the gun, grip it firmly to prevent reaction force. ▪ Electrocution HAZARD Do not direct the jet towards electrical equipment
LOCATION AND/OR PHOTO IDENTIFICATION	

REFERENCE	<p>P3</p>
DESCRIPTION	<p>Pictograms on the back of the machine providing safety instructions on the position and use of the parking brake</p>
EXPLANATION OF THE DANGER	<ul style="list-style-type: none"> ▪ General DANGER Read the manual before using the machine ▪ DANGER of unintended machine movement It is necessary to apply the parking brake whenever there is a slope on the machine's parking surface, or the possibility of accidental movement of the machine. This locks the rear axle of the cleaner, preventing accidental and dangerous movement. Apply the brake both when working and whenever the machine is switched off or left by the operator.
LOCATION AND/OR PHOTO IDENTIFICATION	

HAZARD SIGNALS	SIGNAL DESCRIPTION
	THERMAL HAZARD (BURNS) This signal is applied to the carpentry in the vicinity of the discharge pipe areas
PROHIBITION SIGNS	SIGNAL DESCRIPTION
	PROHIBITION OF REMOVAL OF PROTECTIVE EQUIPMENT This sign is applied in the vicinity of the guards or protective devices and indicates the prohibition of their removal while the line is in use.
OBLIGATION SIGNALS	SIGNAL DESCRIPTION
	OBLIGATION TO READ THE INSTRUCTION, USE AND MAINTENANCE MANUAL This sign is attached to the clamps and obliges the operator to read the instructions in the operating and maintenance manual.

ATTENTION



It is **ABSOLUTELY FORBIDDEN** to remove or damage the safety signs on the machine.

CHAPTER 4 - RESIDUAL RISKS

Despite the safety precautions taken by the manufacturer during the design and production phases, during the normal production cycle the machine still presents certain risks that are considered residual. This chapter lists the residual risks and the rules to be observed in order to avoid situations that are hazardous for the operator, the machine and the surrounding environment due to the presence of these residual risks. In order to deal with these residual risks, the end user must have suitable PPE (Personal Protective Equipment) available and follow the instructions for use in this manual.

The residual risks are indicated directly on the machine by means of warning signs:



HIGH TEMPERATURES

Thermal risk due to contact with hot parts



FIRE

Fire hazard if fuel escapes from the tank during use or refuelling



BURST FLUID UNDER PRESSURE

Risk of high-pressure water leakage. A leak or rupture in a pipe can create a risk of injury and skin infection



HANDLING THE MACHINE

The handling and lifting of the machine, during installation, must only be carried out by personnel trained and qualified by the Manufacturer.



Exhaust of combustion gases;

Exhaust fumes are toxic. Do not breathe exhaust fumes. Never obstruct the exhaust gas openings

NOTE



THE OPERATOR WHO IS TO WORK ON THE MACHINE ***MUST RECEIVE*** ADEQUATE INFORMATION ON THE RESIDUAL RISKS TO HEALTH AND SAFETY AT WORK ASSOCIATED WITH THE ACTIVITY IN ORDER TO AVOID POSSIBLE ACCIDENTS.

CHAPTER 5 - PERSONAL PROTECTIVE EQUIPMENT

When operating the machine or during maintenance, personal protective equipment must be worn, such as:

- Safety overalls;
- Protective gloves against thermal and mechanical hazards;
- Eye protection;
- Face shield;
- Non-slip shoes;
- Use of hearing protectors for sound levels above 80 dB

Before use, check that all personal protective equipment is in good condition

CHAPTER 6 - INTENDED AND UNINTENDED USE

The GPW 120.9 SP H hot water high-pressure washer is intended exclusively for cleaning and washing with hot or cold water of objects or surfaces that are suitable for mechanical treatment with the high-pressure water jet.

Any use other than that for which the machine was designed represents an abnormal condition and may cause damage to the work equipment and constitute a serious hazard to the operator.

Improper use means the use of our machines for operations for which they have not been constructed, i.e:

- washing objects or vehicles that have come into contact with flammable, aggressive, noxious or explosive dusts, gases or liquids or that otherwise give rise to dangerous reactions in contact with water;
- use in places with a risk of explosion or increased risk of fire;
- use for cleaning animals of all sizes;
- use by non-adult persons, i.e. under 16 years of age;
- use in rain or thunderstorms;
- use for washing any device powered by electricity;
- use by untrained personnel.

NOTE



THIS MANUAL IS AN INTEGRAL PART OF THE MACHINE AND MUST ALWAYS ACCOMPANY IT, EVEN IN THE EVENT OF TRANSFER OF OWNERSHIP.

6.1 USE IN CLOSED ENVIRONMENTS

If the machine is located in an enclosed area, the adapter for the smoke exhaust chimney (code 5000030) must be fitted.

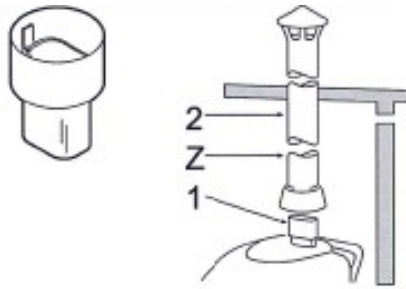

If the machine is located in an enclosed area, it must be well ventilated and it must be ensured that exhaust gases are adequately eliminated



ATTENTION



The diameter (Z) of the chimney (2) must not be smaller than that of the adapter (1). It is advisable to install a chimney for exhaust gas extraction as shown in the figure.

6.2 USE IN LOCATIONS SUBJECT TO WIND OR STRONG AIR CURRENTS

If the machine is positioned in a place subject to wind or strong air currents, the adapter for the smoke exhaust chimney (code 5000030) must be fitted as in Figure

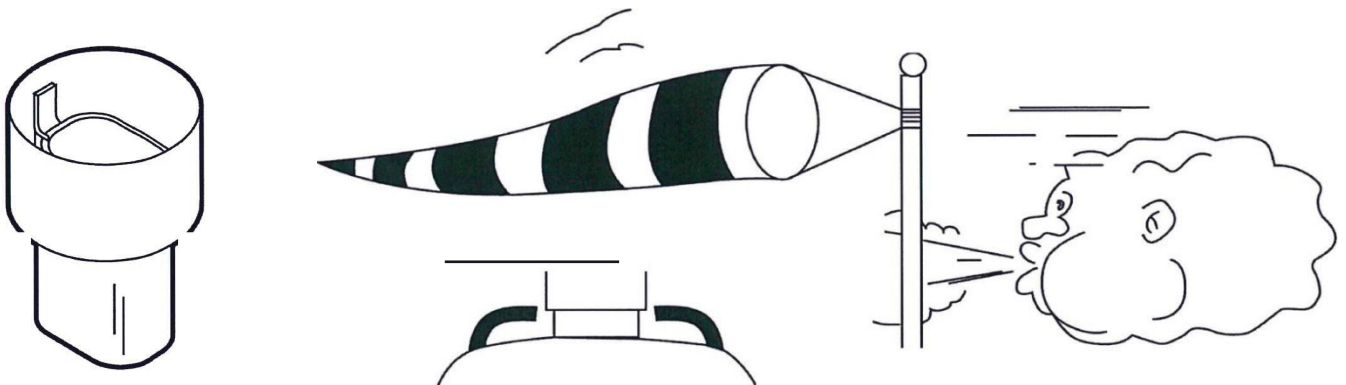

WARNING



This precaution will prevent serious damage to the machine

6.3 CONTRAINDICATION AND HAZARDS DUE TO UNINTENDED OR MISUSE

1. Any operation not mentioned in this manual is considered to be an improper use of the machine which could cause damage to persons and/or property.
2. The machine has not been built to work in an explosive environment, **SO IT IS ABSOLUTELY FORBIDDEN TO USE THE MACHINE IN AN EXPLOSIVE ATMOSPHERE.**
3. During machine operation, never remove or circumvent the protective systems fitted to the machine.
4. All the elements which are not described in this manual may only be adjusted or modified by the manufacturer's personnel or by qualified personnel working under the supervision of the manufacturer's technicians. With regard to components to be traded, please observe the relevant instruction manuals.
5. For any unintended use of the machine, or in any case for any work to be carried out on it, the user is obliged to contact the manufacturer to find out about any contraindications or hazards deriving from improper use of the machine.
6. It is absolutely forbidden to modify the functional and performance characteristics of the machine and/or its main components in order to increase its production potential.

Incorrect use of the machine can be:

- incorrect connection and/or use of the supplied or optional accessories,
- incorrect sequence of commissioning manoeuvres,
- failure to use original spare parts,
- repairs carried out by unauthorised personnel,
- maintenance work carried out by unqualified personnel,
- uses for which the machine was not designed (see improper use),
- lack of maintenance,
- use of the power supply cable or high-pressure water outlet hose to tow the machine.



CHAPTER 7 - TECHNICAL DATA

7.1 ENVIRONMENTAL REQUIREMENTS

The GPW 120.9 SP H hot water pressure washer has been designed and manufactured to be used in the following environmental conditions.

- Maximum temperature +50°C
- Minimum temperature +1°C
- Relative humidity 80%

7.2 DIMENSIONS AND TECHNICAL DATA

Table 1 - DIMENSIONS AND TECHNICAL DATA (*) = 60 Hz version available on request

Line		230 V Single-phase
Technical Data (I)	Units	GPW 120.9 SP H
Scope	L/min	9
Pressure	Bar	120
Maximum pressure	MPa	12
Power	kW	2.2
T° Max. inlet H2O	°C	50
Max. outlet temperature H2O	°C	90
Burner power	Kcal/h	47.000
Burner fuel type	-	diesel
Fuel tank volume	litres	24
Maximum H2O input pressure (water mains or system)	MPa	0,5
Gun repulsive force at maximum pressure	N	43.69
Engine insulation	-	Class F
Engine protection	-	IP54
Voltage / Frequency (*)	V/Hz	230/50
safety valve - intervention pressure (110% Press. Max.)	Bar	132
Sound emission level:		
Sound pressure at operator: LPA (EN 3744) K = 3 dB(A)	dB (A)	84.4
Sound Power: LWA (EN 3744) K = 3 dB(A)	dB (A)	97
Hand-arm vibrations K=1.5 M/s2	M/s2	1.16
WEIGHT	Kg.	103
DIMENSIONS (WxDxH)	mm	1000 x 670 x 720

CHAPTER 8 - COMMISSIONING THE MACHINE

8.1 PREVENTIVE CHECKS AFTER RECEIPT

Upon receipt of the goods, check the condition of the package; if any damage is found, refrain from any installation procedure and notify the carrier and supplier immediately.

Ascertain the good condition of the package, proceed to unpack the goods and check that the delivery is complete (check correspondence with the delivery note); ensure that the general condition of the machine is good and that there are no breaks or dents.

In the event of shortages or damage, notify the dealer and/or manufacturer immediately after making any legal reservations with the carrier or companies authorised for this purpose; it is strictly forbidden to dispose of the material in the environment.

8.2 CHECKING THE MACHINE STATUS

Following the document check, in order to detect any damage caused by transport, it is advisable to carry out a thorough check of the condition of the machine.

If the packaging is damaged, take the following action:

- ❑ **EXTERNALLY RECOGNISABLE DAMAGE OR MISSING INDIVIDUAL ITEMS:** these must be declared immediately after delivery to the courier or carrier, etc., and confirmed in writing in the consignment note;
- ❑ **DAMAGE THAT IS NOT IMMEDIATELY RECOGNISABLE:** this must be declared to the carrier, or transporter, etc., within the time limits permitted by law.
- ❑ **SERIOUS DAMAGE:** an expert's report by a technical expert appointed by the carrier, the courier or the respective insurance company is required.

ATTENTION



It is forbidden to tow the machine by the power supply cable and/or by the high-pressure water outlet rubber hose.

WARNING



Complaints about missing equipment must be made within the time limits set out in the purchase contract.



If the machine has to be moved manually from one place to another, you must disconnect the plug from the power socket, then, using the special handle and taking care not to make any sudden movements that may compromise your safety, that of others and the integrity of the machine itself, proceed to move it.

NOTE



The machine is normally sent with non-returnable packaging. Packaging materials should be collected and disposed of separately and sent to specialised waste disposal companies (wood, plastic, metal, etc.) and not left within reach of children or animals.

CHAPTER 9 - HANDLING AND INSTALLATION OF THE MACHINE

9.1 PRELIMINARY OPERATIONS

The machine was tested in the manufacturer's factory to verify the correct functioning of all components according to the specifications in force. No preliminary operations are required.



9.2 LIFTING

If the machine is to be transported, it must be secured by means of straps, ropes or other suitable means in a stable and safe manner to prevent accidental movement from causing damage to persons or property as well as to the machine itself.

If the machine has to be lifted, it must be attached to the lifting equipment by means of straps or suitable equipment that safeguards its integrity. Ensure that the equipment used has a capacity greater than the weight and volume of the machine; it is recommended that efficient equipment be used in accordance with the safety operating rules in force.

ATTENTION



It is absolutely forbidden to stand under or in the immediate vicinity of the machine while it is being lifted and moved.

Be wary of bent and shrivelled chains or ropes, always use thick work gloves.

Chains or ropes must be firmly attached.

Make sure that the attachment is strong enough to support the intended load....

9.3 TRANSPORT

The machine can be moved on the ground using its own wheels and by pushing on the rear handle.

9.4 FREE SPACES OF RESPECT

The machine requires at least 1000 mm (measured with all movable guards in the open position) of free space in relation to the maximum overall dimensions for correct operation and maintenance without the risk of obstruction by other elements.

ATTENTION



The floor of the place where the machine is to be installed or operated must be even, well levelled and suitable for bearing the loads of the machine.

CHAPTER 10 - CONNECTIONS TO EXTERNAL ENERGY SOURCES

10.1 ELECTRICAL CONNECTION

It is compulsory to connect the machine to an electrical network with an earthing system with a resistance value capable of guaranteeing a contact voltage not exceeding 25 V.

The installation must be carried out in such a way that the connections are not damaged by people or things and, as far as possible, must be carried out away from transit routes.

Check that the electrical outlet has the required characteristics of conformity and the appropriate differential protection, in accordance with the standards in force, then connect the outlet (11) Pag. 16.

IMPORTANT NOTE:

.Depending on the country where it will be used, the user should check on site what type of network is present (TN, TT, IT system) and if necessary, install a differential.

- *TT system: Protection against contact voltages is only ensured by using the residual current device.*
- *TN system, earth leakage circuit breakers should only be used in special cases, such as in small cross-sections and very long circuits where the above condition cannot be met.*
- *the IT system does not require earth leakage circuit breakers, as they can compromise the continuity of operation that led to the choice of the IT system.*

Avoid the use of extension cords as far as possible.

WHEN MAKING THE ELECTRICAL CONNECTION, OBSERVE THE VOLTAGE AND FREQUENCY VALUES AS STATED IN THIS MANUAL AND ON THE CE LABEL.

THE ELECTRICAL CIRCUIT DIAGRAM IS ATTACHED TO THE DOCUMENTATION SUPPLIED WITH THE MACHINE.

ATTENTION



Connection to the electrical power supply and the earthing system should be carried out by qualified and experienced personnel, in accordance with the regulations in force.



The electrical power network must be fitted with a circuit breaker suitable for the machine's power rating. In addition, a high-sensitivity residual current circuit breaker with trip threshold $I_{dn}=0.030$ A must always be installed.

10.2 WATER CONNECTION

At the front of the machine there is a water inlet connection.

Connect a water supply hose (not supplied) to the inlet fitting (3 in the figure) and the other end of the hose to the tap, which must guarantee a minimum flow rate equal to that of the pump

THE HYDRAULIC CIRCUIT DIAGRAM IS ATTACHED TO THE DOCUMENTATION SUPPLIED WITH THE MACHINE.

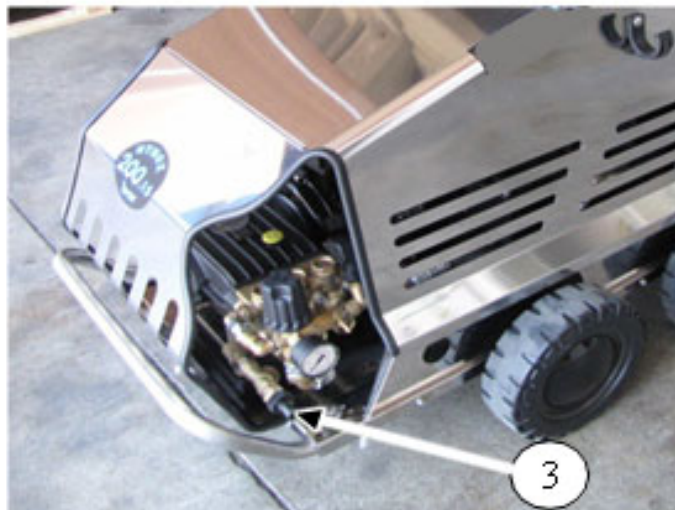

ATTENTION



All work on the connection of the machine to external energy sources must be carried out by qualified personnel, in compliance with current regulations and under the supervision of the manufacturer's technicians.



Pneumatic hoses sized for the same or higher pressures should be used for connection.

CHAPTER 11 - CONTROL PARTS

11.1 CONTROL STATION

The control station is the place where the operator must be to manage the work cycle and supervise the machine's operation.

The machine is equipped with:

- **NO. 1 COMMAND AND CONTROL PANEL**



Key:

- A. Pump engine start light switch (in)
- B. Burner ignition light switch (br)
- C. Adjusting the burner outlet water temperature (tr)
- D. Warning light

ATTENTION



During operation, no-one other than the operators in charge must stand near the machine or, worse still, intervene on it.



The protections have been designed by the manufacturer in order to safeguard the safety of the operators while carrying out their tasks. During operation, the guards must not be removed for any reason.

Control devices

11.1.1 CONTROL PANEL

REFERENCE	A
CONTROL PART	Pump engine start light switch (in)
DESCRIPTION	Controls the switching on of the pump engine and the switching on of the corresponding warning light

REFERENCE	B
CONTROL PART	Burner ignition light switch (br)
DESCRIPTION	Controls the ignition of the burner and the switching on of the relevant indicator light

REFERENCE	C
CONTROL PART	Thermostat (tr)
DESCRIPTION	Thermostat to select the temperature of the water leaving the burner.

ATTENTION



The adjustment operations described in this chapter must be carried out **ONLY** by qualified and authorised personnel.



Use protective devices during maintenance, replacement and adjustment operations.



Before starting work, always check that no hazardous conditions exist in the working area.
NEVER LEAVE THE PRESSURE WASHER WITH THE ENGINE RUNNING.

WARNING



NEVER START the pump dry as this could cause damage to the pump. If the pump does not suck in water, switch off the engine immediately.

CHAPTER 13 - USE OF THE MACHINE

13.1 DESCRIPTION OF THE OPERATING CYCLE

The cold water pressure washer, once connected to the power sources (hydraulic and electrical), is ready to deliver the water flow and pressure once turned on.

13.1.1 COLD WATER OPERATION

1. Fully open the water tap on the mains water supply.



2. Disengage the safety catch, open the gun, and hold it open for a few seconds to allow any air and residual pressure to escape from the pipes. Operate the gun lever (3) to dispense water from the lance (4).



3. Start the pump motor unit by pressing the appropriate switch (in) on the electrical control panel. The corresponding indicator light (a) will come on.



13.1.2 HOT WATER OPERATION

Check that the diesel tank is full (1); if not, fill it up using diesel fuel only.

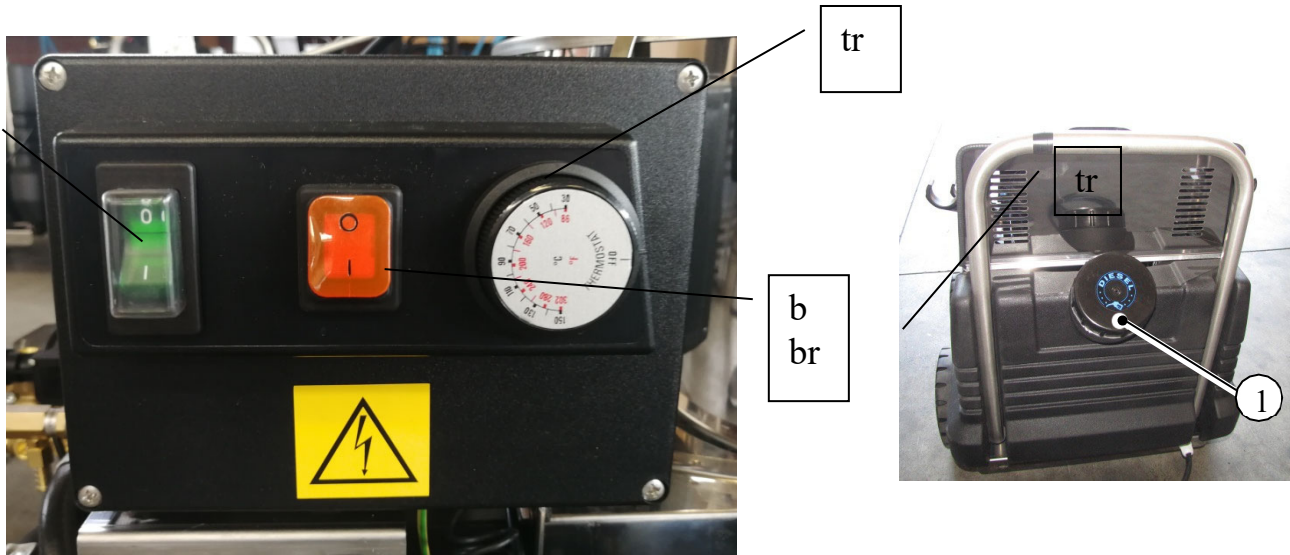

- Repeat steps 1, 2, and 3 for cold water operation (previous paragraph).
- Check that the thermostat(**tr**) is set to 0°C (OFF).
- Switch on the burner with the burner switch (**br**), the corresponding indicator light (**b**) will light up,
- Wait 30 seconds for the diesel pump to fill up. (this pump is equipped with a pressure gauge to monitor the operating pressure. The standard operating pressure is set between 9 and 10 bar)
- Using the thermostat(**tr**), turn the knob to the desired temperature (once the required temperature has been reached, the burner will automatically stop and then switch on again whenever the temperature drops).
- Act on the gun lever(**3**) to obtain water delivery from the wand,
- Ensure that this forms a uniform fan (**4**), exiting the wand and then start work.





Diesel pump pressure gauge

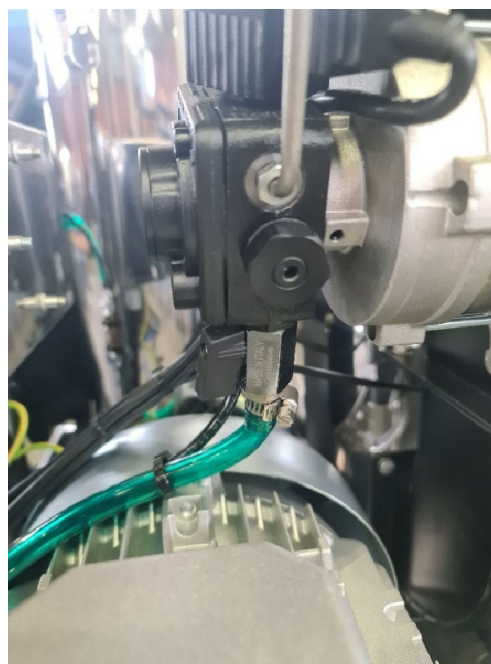

Ball valve for diesel fuel supply interruption

At the end of the work:

- Reset the thermostat(**tr**),
- Keep the gun open (**3**) and allow the water to cool;
- Act on the burner off switch (**br**),
- Close the water supply tap (**2**),
- Close the fuel sectioning ball valve.
- Act on the switch (**in**) to deactivate the engine/pump unit
- Actuate the gun lever (**3**) in order to release the residual pressure.

ATTENTION



The use operations described in this chapter must be carried out **ONLY** by qualified and authorised personnel.



Use personal protective equipment during operation.



If there are micro leaks, the machine switches off and the indicator light (e) flashes:

- check the machine's high-pressure water circuit
reset by pressing the switch (in).



- The machine is equipped with the TDS system (Total Stop Timed): it switches off when the water gun is closed, after 15 seconds and the indicator light (d) comes on.

13.1.3 USE WITH CHEMICAL PRODUCT

With the machine switched on, without operating the gun, turn the black adjustable head anti-clockwise to draw in the detergent. When you have finished dispensing the detergent, screw the adjustable head back in clockwise to work in more pressure and rinse.



Figure 4.7

When doing so, carefully follow the information on the product labels, both with regard to safety and with regard to the percentages to be observed when diluting. Fill the detergent container(5) with the product you intend to use for the application to be carried out and immerse the detergent suction tube with its filter in it.



DETERGENT

Repeat steps (1) (2) and (3) already carried out for cold water use.

During work, the detergent will be sucked in and automatically mixed with water.

- **Practical advice**

Avoid wetting the surface to be treated with the detergent with water, as this will leave a film of water in the way of the product, which will result in poor cleaning results; instead, wait for the chemical to come out of the nozzle while keeping the nozzle pointed towards the ground. When the detergent reaches the outlet, approach the surface to be treated and, starting from the bottom and in overlapping bands approaching the top, sprinkle the entire surface with the detergent. In order to avoid deposits or scaling, it is advisable to have the pump suck clean water for a few seconds after work is completed.

- **Important tips**

To protect the environment, we recommend using only approved detergents, observing the recommendations for use and dosage on the packaging labels, using detergent sparingly and remembering that unsuitable detergents, as well as causing damage to the environment, can also damage the pressure washer and the objects to be cleaned. Before spraying detergent on delicately coloured paintwork, make sure that the surfaces to be treated are not hot, that the detergent does not dry out and that the water/ detergent dilution is correct. It is recommended to rinse well, thoroughly and without leaving any residue. When the work is finished, switch off the machine and then operate the gun lever in order to release the residual pressure.



During operation, use suitable personal protective equipment such as gloves against chemical hazards.



For environmental protection: Use detergents that are 90% biodegradable.

WARNING

The machine is designed to work on flat surfaces.

If the machine must be parked on a slope, the parking brake must be engaged by unscrewing the knob on the back of the vehicle. This will allow the brake system to act directly on the two rear axle wheels, preventing them from rotating.



Detail of the brake knob being locked on the rear axle

To release the parking brake, turn the knob clockwise to move the brake bar away from the rear axle wheels.



Detail of the brake being released on the rear axle

13.2 CONTRAINDICATIONS TO USING THE MACHINE

Full compliance with the Machinery Directive 2006/42 EC and the efforts made by our engineers during the design phase have resulted in a machine that can be placed at the highest safety level for its category. Each of the mechanical, electronic, control, etc. parts, devices or arrangements with which the machine is equipped has been designed taking into account all possible risks that could potentially arise.

Wherever possible, using the best technological resources available today, these risks have been eliminated by applying appropriate protection or technical measures.

Furthermore, in order to avoid machine malfunctions and further risks of injury, it is recommended that the following provisions be scrupulously observed:

- Do not use the machine for purposes other than those for which it has been built
- The machine must be stopped normally using the controls on the panel.
- Do not approach the machine with explosive or flammable materials.
- Do not operate the machine while wearing loose clothing or objects such as scarves, necklaces, ties, etc., which may become entangled or close to potentially hot surfaces
- The protections provided by the manufacturer have been designed to protect the safety of the operator and it is therefore recommended not to tamper with or remove them for any reason.



ATTENTION



The operations described in this chapter must be carried out **ONLY** by qualified and authorised personnel.



The use of protective equipment is **MANDATORY** during the operations described in this section.

CHAPTER 14 - MAINTENANCE

Maintenance is a set of periodic and predefined operations aimed at maintaining the functionality of the machine in all its aspects, as a result of the wear and tear inherent in its use.

The various routine maintenance operations are described below. Please note that lower operating costs and a long service life of the machine depend on continuous compliance with this manual.

For extraordinary maintenance operations not covered in this manual, contact the manufacturer.

CAUTION: all the operations described in the following paragraphs must be carried out with the machine switched off and the electrical system disconnected.

14.1 PRESSURE WASHER CLEANING

Wash with neutral products and water only, then dry thoroughly to remove any water pockets.

Plastic parts should be cleaned in a normal washing procedure.

If there are still traces of dirt, we recommend the use of specific products, carefully observing the manufacturer's instructions.



Do not use products containing solvents, methanol or hydrocarbons.

14.2 MAINTENANCE INTERVALS

DAILY: Check the high-pressure hose for damage (burst hazard).

WEEKLY: Check oil level. In the event of milky oil (water in the oil), contact Customer Services immediately.

MONTHLY: Clean the water filter; Clean the filter on the detergent suction hose Check for cracks in the fasteners between the engine and the frame, ask the customer service department to replace the cracked fasteners.

AFTER 500 HOURS or



ONCE A YEAR: Have the appliance serviced by the service department

14.3 PUMP LUBRICATION

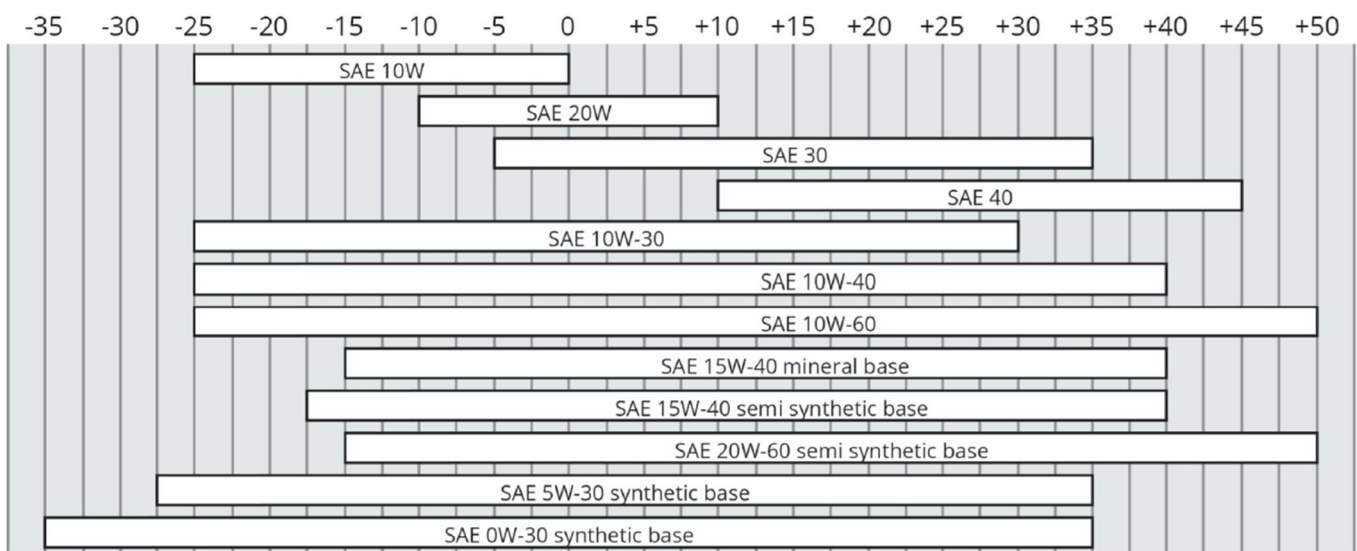
Change the oil after the first 50 hours of operation and every 500 hours thereafter. The recommended oils are shown in the table below.



14.4 ADJUSTING THE IGNITION ELECTRODES

OPERAZIONE EFFETTUATA SOLO DA CENTRO DI ASSISTENZA

For optimum operation of the machine, it must be checked that the ignition electrodes are always arranged correctly, as shown in the diagram.

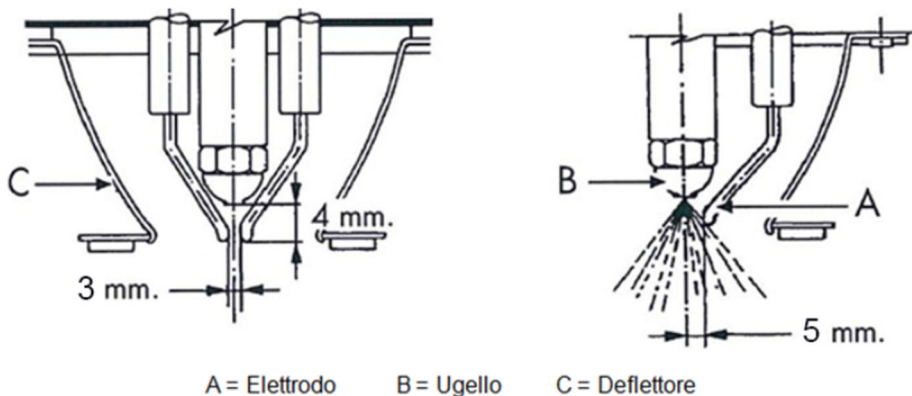

Replace the ignition electrodes every 400 operating hours.

ATTENTION



The operations described in this chapter must be carried out **ONLY** by qualified and authorised personnel.



The use of protective equipment is **MANDATORY** during the operations described in this section.

14.5 TROUBLESHOOTING

The tables below list the main malfunctions, with their causes and recommended remedies, that the machine may present during operation.

Any work required must only be carried out by experienced and qualified operators after having read this manual.

PROBLEM	CAUSE	SOLUTION
The pump runs but does not reach the prescribed pressures.	The pump sucks in air.	Check the intake ducts and ensure good tightness
	Worn valves.	Replace the valves.
	Worn control valve seat.	Replace the valve seat.
	Worn or inadequate water nozzle	Replace the water nozzle.
	Worn gaskets.	Replace the seals.
	Dirty water filter	Clean the water filter.
Irregular pressure fluctuations.	Worn suction and/or discharge valves.	Replace the valves.
	Presence of foreign bodies in the valves that impair their function.	Check and clean.
	Air intake.	Check the intake ducts.
	Worn gaskets.	Replacing seals
Pressure drop.	Worn suction and/or discharge valves.	Replace the valves.
	Presence of foreign bodies in the valves impairing operation.	Check and clean.
	Air intake.	Check the intake ducts.
	Worn gaskets.	Replacing seals

PROBLEM	CAUSE	SOLUTION
Regular pressure at pressure gauge, pressure drop	Lime scale in the circuit.	Check and clean; we recommend our technician.
The boiler produces excess smoke.	Presence of water in the diesel tank.	Empty the tank and fill it with pure diesel fuel.
	The diesel pressure is not correct.	Restore the correct pressure by turning the adjusting screw to approximately 10 bar.
	The ignition electrodes are not in the correct position.	Adjust the distance between the electrodes.
	The diesel fuel nozzle is dirty.	Clean the diesel fuel nozzle.
	The diesel fuel nozzle is worn.	Replace the diesel nozzle.
	The diesel pump is dirty.	Clean the diesel pump.
The burner switches off.	The diesel tank is empty.	Fill the tank.
	The filter on the diesel suction pipe is dirty.	Clean the diesel fuel filter.
	Presence of water in the diesel tank.	Empty, clean and fill the tank with pure diesel fuel.
	The pressure switch does not work .	Replace the pressure switch.
	Ignition transformer failure.	Replace the ignition transformer.
	Incorrectly positioned ignition electrodes.	Reposition the ignition electrodes in the correct position.
	The diesel fuel nozzle is dirty.	Clean the diesel fuel nozzle.
	The diesel fuel nozzle is worn.	Replace the diesel nozzle.
	The diesel pump is damaged.	Replace the diesel pump
	The diesel solenoid valve is damaged.	Replace the diesel solenoid valve.
	Worn fuel pump plastic sea.	Replace.
	Burner motor damaged.	Replace.
	Thermostat damaged.	Replace.
	Burner switch damaged.	Replace.
Electronic circuit board damaged.	Replace.	
Photocell damaged.	Replace.	

PROBLEM	CAUSE	SOLUTION
Presence of water in the pump oil	Worn crankcase side seal ring.	Replace the sealing ring.
	Gaskets completely worn.	Replace the seals.
Noise	Air intake.	Check the tightness of the intake ducts.
	Dirty water filter	Cleaning the water filter
	Insufficient water supply	Ensure that the machine has a water supply greater than the pump's capacity.
	Intake and/or discharge valve springs broken or worn out.	Replacing valves
	Foreign bodies in the suction and/or discharge valves.	Check and clean the valves
	Worn bearings.	Replace the bearings.
Water leaking from drains between crankcase and pump head	Worn gaskets.	Replace the seals.
	Worn piston.	Replace the piston.
	Worn valve cap O-ring.	Replace the valve cap O-ring.
Oil leaking from the drains between the crankcase and the pump head	Worn crankcase side sealing rings.	Replace the sealing rings.
Excessive vibration at discharge.	Worn or dirty valves.	Replace the valves.
The electric engine does not start.	No power supply.	Check if the plug is properly inserted in the socket and if there is current on the line.
	The circuit breaker has tripped	Check the circuit breaker.
Insufficient water temperature.	Thermostat not adjusted to the required temperature	Set the thermostat to the required temperature.
	Thermostat failure.	Replace the thermostat.
	Scale deposits in the hydraulic circuit.	Clean.
	Boiler partially clogged with soot.	Clean.

CHAPTER 15 - DISPOSAL

15.1 PRESSURE WASHER DISPOSAL (DEMOLITION OF THE MACHINE)

If you decide to scrap the machine, to prevent it from posing an hazard to people and the environment, it is necessary:

- disconnect the machine from the mains power supply and from the water supply network
- cut the power supply cable and piping
- remove the wand and gun
- cutting electrical wiring
- Disassemble and disconnect the pump and engine from each other
- destroy the identification plate of the machine and that of the pump and engine unit.
- Sheaths, flexible conduits and components made of plastic or non-metallic material must be dismantled and disposed of separately.
- Electrical components such as switches, power supplies, cards, etc., must be dismantled for reuse if they are still in good condition or, if possible, overhauled and recycled.
- The structure, and in any case all the metal parts of the machine, must be dismantled and grouped by type of material. The various parts thus obtained can then be dismantled and melted down to allow the recycling of the original machine material.

All fluids used in the machine's piping must be removed and disposed of in accordance with current regulations.

The machine must be dismantled by specialised personnel.

The components of the pressure washer must be disassembled and separated according to the nature of the materials that compose it, and must be disposed of in compliance with the laws in force regarding the collection and separate disposal of waste.



If the machine is dismantled, comply with the anti-pollution regulations in force in the country of use. Failure to comply with these provisions can cause considerable damage to people, animals and the environment.

The End-customer is responsible for any failures and non-compliance with these rules.

15.2 DISPOSAL OF CONSUMABLES OR MATERIALS SUBJECT TO WEAR AND TEAR

With regard to the disposal of parts subject to increased wear, which may have been replaced, no particular recommendations are necessary other than to follow the regulations in force at the place of operation of the machine regarding the separate collection of waste.

Waste oil must be disposed of through the waste oil consortium, in accordance with the law.

15.3 . DISPOSAL OF PACKAGING

Packaging materials and maintenance waste should be collected separately and sent to specialised waste disposal companies (wood, plastic, metal, etc.) and not left within reach of children or animals.

CHAPTER 16 - TEMPORARY DECOMMISSIONING OF THE PRESSURE WASHER

If you decide to keep the machine idle for a long period of time, it is advisable to carry out some operations to keep the machine in good condition.

It is necessary to:

- End a work cycle.
- Switch off the machine and remove the connections to the water mains and the connection to the power socket
- Empty the hydraulic circuits and the diesel tank.
- Store the machine in a place protected from the elements
- cover with a cloth to protect against dust.

Carry out these operations with care so that the equipment is in optimum condition when the work is resumed

CHAPTER 17 - SOUND EMISSION

The Leq equivalent level averaged over multiple processing cycles (including footwear change stages) was measured with Class 1 precision sound level meter as set out in IEC standards with fast-slow reading constant, both from the position where the operator is, and in positions surrounding the machine being considered. There is a phonometric report at the company.

In view of the results of continuous use of the machine, the use of anti-noise devices such as ear plugs or ear muffs is mandatory.

The measured value is $L_p(A) = 84.4$ dB and the sound power level is $L_w = 97$ dB

	Misura 1	Misura 2	Misura 3	Misura fondo	Unità di misura
Punto di misura	Lp 1	Lp 2	Lp 3	$L_{p, fondo}$	
Punto 1	85.3	82.6	82.9	60.1	(dBA)
Punto 2	82.3	85.3	86.3	54.6	(dBA)
Punto 3	81.0	82.3	82.0	53.8	(dBA)
Punto 4	81.6	83.1	83.4	53.1	(dBA)
Punto 5	83.3	85.0	83.6	56.6	(dBA)
Punto 6	81.3	82.5	81.0	55.2	(dBA)
Punto 7	83.9	83.4	83.7	57.0	(dBA)
Punto 8	83.6	85.7	85.5	53.9	(dBA)
Punto 9	84.1	85.3	82.0	55.5	(dBA)
$L_{p, Medio}$	83.1	84.1	83.7	56.1	(dBA)
Dev, st	0.40	(dBA)			
Max Var	0.4	(dBA)			
Media due più alti	83.9	(dBA)			
K_1	0.0	(dBA)			
K_2	0.0	(dBA)			
$L_p - k_1 - k_2$	83.9	(dBA)			
Superficie	20	m^2			
$10\log(S/S_0)$	13.0	(dBA)			
L_w	96.9	(dBA)			
L_w (arrotondato)	97	(dBA)			
Incertezza - $u(L_{wA})$	1.17	(dBA)			

Livello di Potenza Sonora
 $L_{wA} = 97$ dBA



CHAPTER 18 - HAND-ARM VIBRATIONS

The level of vibration transmitted to the hand-arm system during the work phase via the wand handle is below the warning limit and is equal to $a_w = 1.16 \text{ m/sec}$ (as shown in the graph above).

MODELLO	GPW 120.9 SP H	
Descrizione: sorgente in normale funzionamento.		
Strumentazione: Sinus - Apollo Sorgente: GPW 120.9 SP H Distanza di misura (dietro): 0,40 m Altezza di misura (pavimento): 1,55 m		

Rumore

Livello di pressione sonora all'operatore **$L_p(A) = 84.4 \text{ dB(A)}$**

Incertezza associata $K_{pA} = 0,75 \text{ dBA}$

Freq (Hz)	L_p (dB)
20	50.5
25	56.9
31.5	56.6
40	60.2
50	66.8
63	65.8
80	76.7
100	80.5
125	72.8
160	68.9
200	67.8
250	66.6
315	66.7
400	66.1
500	72.9
630	71.6
800	69.2
1000	71.3
1250	69.9
1600	70.3
2000	73.7
2500	75.2
3150	74.0
4000	74.5
5000	74.2
6300	72.6
8000	71.3
10000	71.0
12500	69.8
16000	67.0
20000	62.5
Total A	84.4
Total C	86.1
Total Lin	86.7

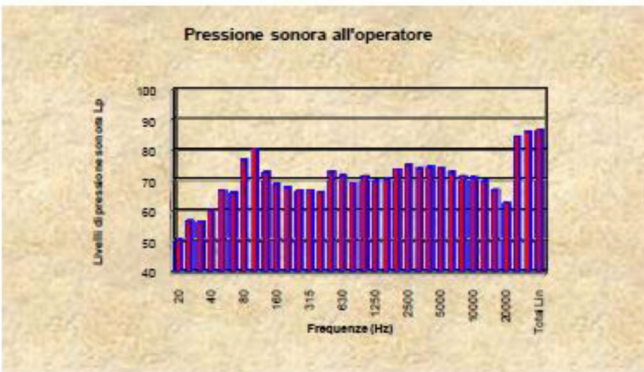

Vibrazioni

Livello di vibrazione trasmesso al sistema Mano-Braccio (ISO 5349)

Asse X	0.83	m/s^2
Asse Y	0.78	m/s^2
Asse Z	0.24	m/s^2
$a_{w,eq}(t)$	1.16	m/s^2

Incertezza associata $K_v = 6,3 \%$

CHAPTER 19 - SUMMARY OF THE MAIN WARNINGS

- The safety devices have been designed by the manufacturer to safeguard the operator's safety while performing his tasks. The devices must not be tampered with under any circumstances during operation.
- Work on the switchboard may only be carried out by qualified electricians.
- Never run the machine with no load.
- During operation, when the machine is running, its surfaces are at high temperature, they **must never be touched with bare hands!!!**
- **Never direct the water jet at yourself or other people: the jet may be at high pressure and cause serious injury**
- It is absolutely forbidden, during machine operation, to remove or tamper with the protective covers provided by the manufacturer in order to safeguard the operator's safety.

CHAPTER 20 - SPARE PARTS

20.1 ORDERING RULES

The various components of the machine can be obtained from your local dealer. Insert in the request:

- **Model and serial number of the machine.** These data are printed on the identification plate of each machine
- The **code number of the required** part can be found in the spare parts catalogue available from your local dealer.
- **Description of the part and quantity required.**

Please note that the manufacturer is always available for any assistance and/or spare parts.

20.2 PERSONAL DATA

An exact description of the model, serial number and any installed accessories will facilitate quick and effective responses from the manufacturer or service centre. Always state the type, model and serial number of the machine whenever you contact the service centre. As a reminder, we suggest that you enter the machine data in this box.

MODELLO	MATRICOLA N°
ANNO DIFABBRICAZIONE	TIPO DI POMPA
TIPO DIMOTORE	

NOTES



The responsibility for any re-use of parts of the machines, e.g. engines or pumps, lies exclusively with the user.



The manufacturer is in no way liable for damage caused by the machine if it is used without certain components or for a purpose not expressly specified in this manual.



IN ANY CASE, IT IS NECESSARY TO COMPLY WITH THE REGULATIONS IN FORCE IN THE USER'S COUNTRY CONCERNING THE DISPOSAL OF MATERIALS WITH WHICH THE MACHINE IS EQUIPPED.

ALL RIGHTS RESERVED.

NO PART OF THIS MANUAL MAY BE REPRODUCED IN ANY FORM WHATSOEVER (PRINT, PHOTOCOPY, MICROFILM OR ANY OTHER MEDIUM), OR PROCESSED, REPRODUCED OR DISTRIBUTED BY ELECTRONIC MEANS.

WIRING DIAGRAM SINGLE-PHASE 230V

WIRING TLR4FTC

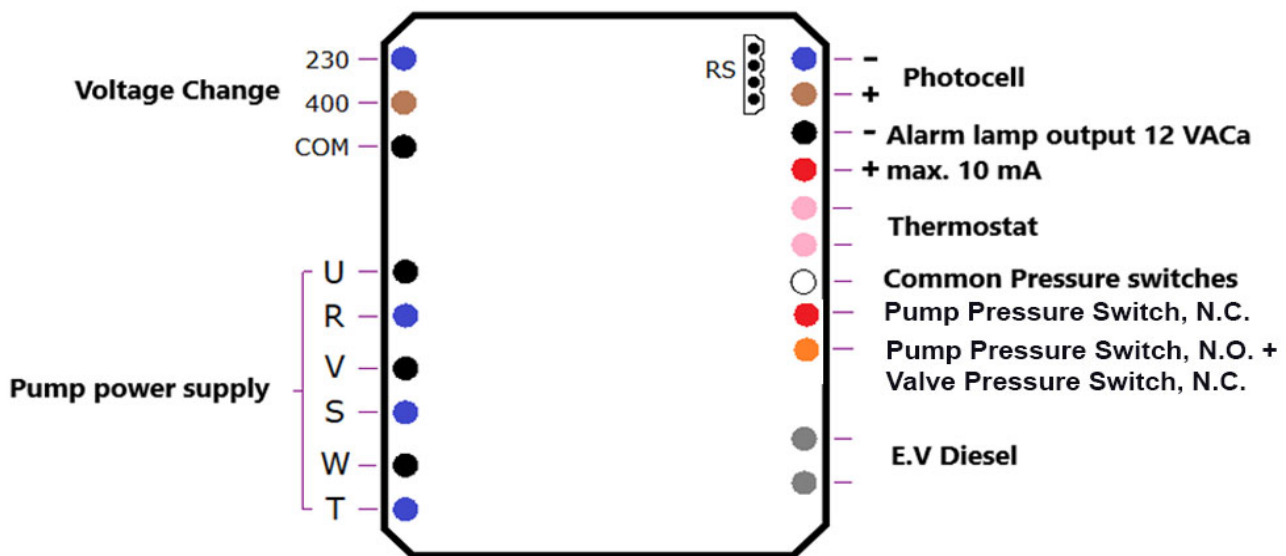

Power supply Input R - S - T
 Motor output U - V - W
 Single-phase version do not use T - W
 RS - Configuration/Control Connector

ALARM WARNING LIGHT:
 On if TOTAL STOP (steady)
 Off if machine is operating under pressure

5 Flashes - no flame
 6 Flashes - photocell error

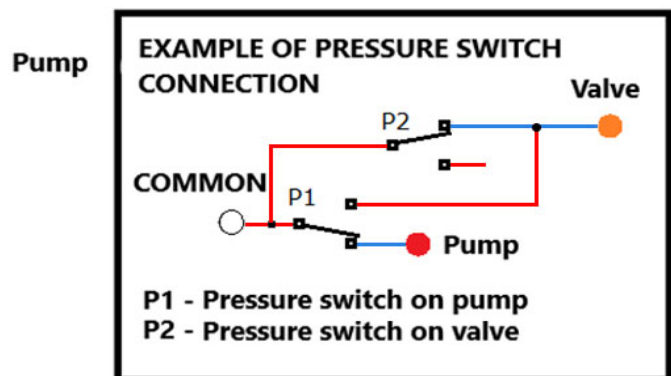

ATTACHMENT - B
WATER SYSTEM DIAGRAM

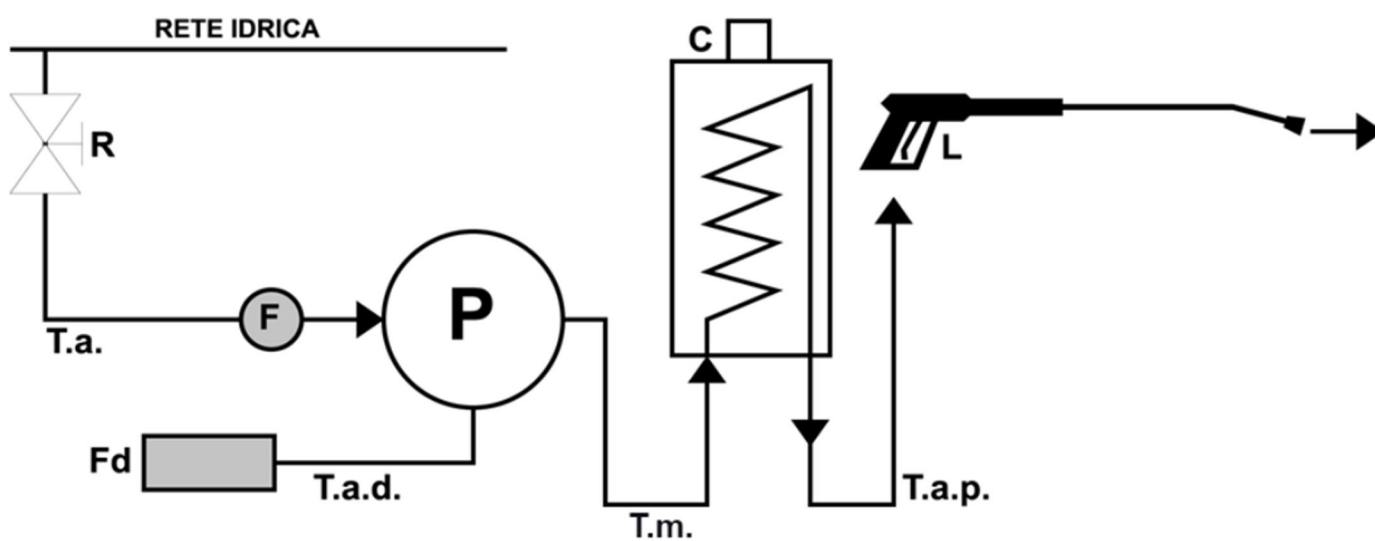

Key:

- R = water tap
- T.a. = water suction hose
- F = filter
- Fd = detergent filter
- T.a.d. = detergent suction hose
- P = water pump
- T.m. = discharge pipe
- C = boiler
- T.a.p. = high pressure water outlet pipe
- L = wand



DICHIARAZIONE DI CONFORMITA'
DECLARATION OF CONFORMITY
allegato II, parte 1.A / annex II, 1.A



PULITECNO dichiara sotto la propria responsabilità che la macchina IDROPULITRICE
modello: **GPW 120.9 SP H**

PULITECNO declares under its own responsibility that the HIGH PRESSURE WASHER machine
model: **GPW 120.9 SP H**

Numero di serie / Serial number _____

Anno di costruzione / Year of construction _____

è conforme alla Direttiva Macchine 2006/42/CE / corresponds to the machines directive 2006/42/CE
2014/30/UE (compatibilità elettromagnetica / electromagnetic compatibility)
2000/14/CE (emissione acustica / acoustic emission)
2011/65/CE (ROHS)
2012/19/CE (RAE/WEEE).

Riferimento norma armonizzata / Reference to the harmonized standard:

EN IEC 60335-1:2023
IEC 60335-2-79:2021
EN 55014-1:2019
EN 61000-3-2:2014
EN 61000-3-3:2013
EN 61000-3-11:2000
EN 60704-1:2018

Dichiariamo inoltre che il marchio CE è apposto sulla suddetta Idropulitrice e questa
Dichiarazione di Conformità viene rilasciata sotto la sola responsabilità del produttore / We
also declare that the CE mark is affixed to the aforementioned Pressure Washer and
this Declaration of Conformity is issued under the sole responsibility of the manufacturer.

Nome e posizione della persona autorizzata a firmare la Dichiarazione e rilasciare il fascicolo
tecnico / Name and position of the person authorized to sign the Declaration and release the
technical file:

Dott. Luca Pedrotti Amministratore Delegato Pulitecno srl – Via Mentovati, 8 – 29122
Piacenza

Firma

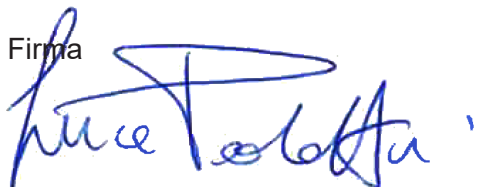

Cod. 49.0390.00 -B- 2^ ed. - 05/2026

DEALER



PULITECNO s.r.l.
via Mentovati, 8 - 29122 Piacenza - Italy

P. +39 0523.577811 - F. +39.0523.577825 - M. comm.ita@pulitecnosrl.it

